

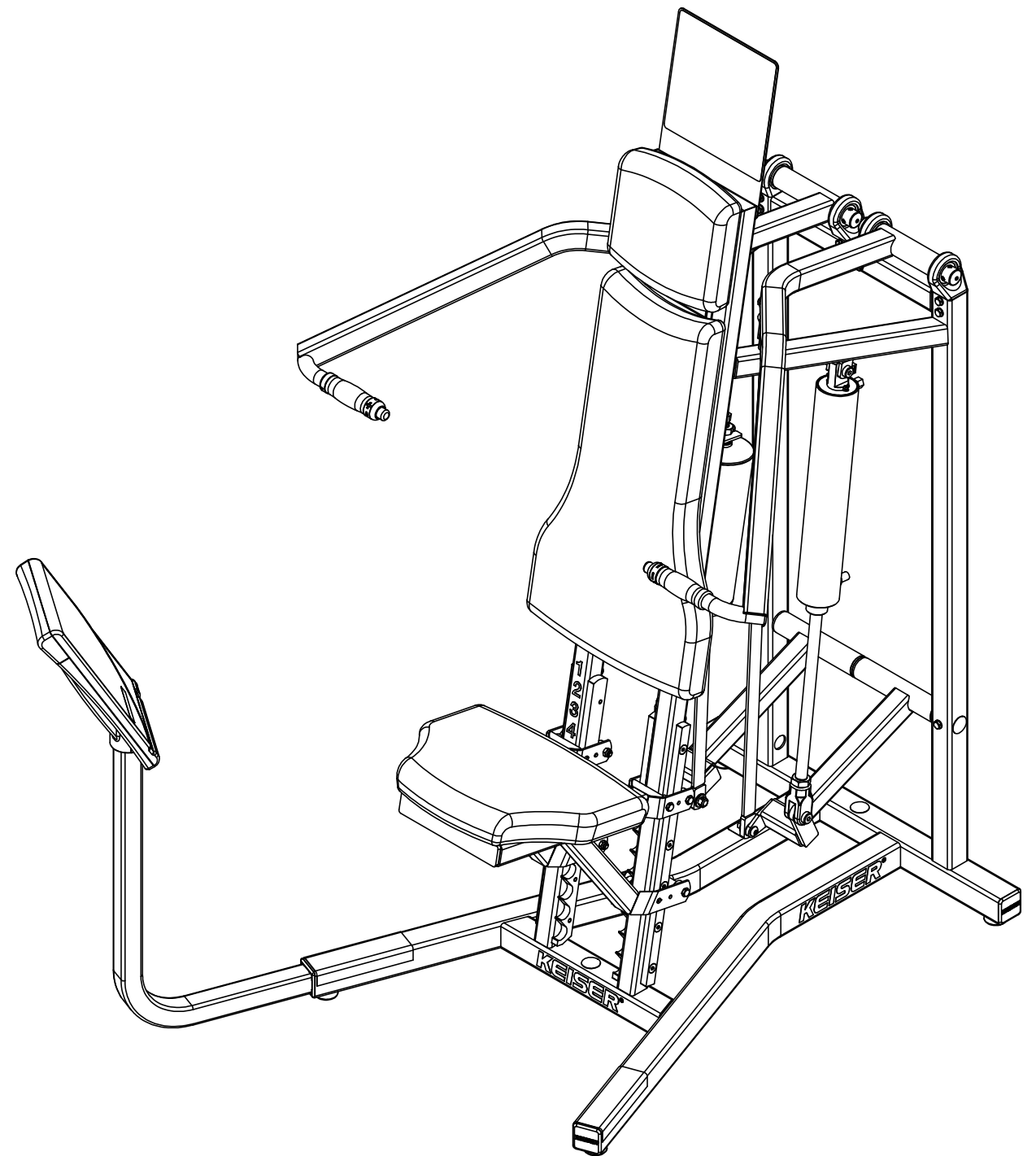

ITEM NO.	QTY.	PART NO.	TITLE	ITEM NO.	QTY.	PART NO.	TITLE
1	4	8079	CON - 3/8C X 1/4M	64	2	160905	DRAG LINK
2	4	9009	PIN SPRING 0063 X 0500 ZP	65	1	162242	SHAFT - PIVOT
3	8	9014	SCREW - HSSS 8-32 X 1/8 SS	66	1	165417	PLACARD - A300 MILITARY PRESS
4	12	9079	SCREW - SFCHCS 5/16-18 X2 1/2	67	1	165501	MANUAL - USER-A300 MILITARY PRESS
5	4	9127	SCREW - SHSS 1/2 X 1 ZP	68	1	170891	ASSY - MUFFLER-LONG
6	4	9174	SCREW - HHCS 5/16-18 X 1/2 ZP	69	1	175051	2 SQ. BUSHING
7	2	9175	SCREW - HHCS 5/16-18 X 3/4 ZP	70	2	255318	TANK - 144 CU IN
8	2	9177	SCREW - HHCS 5/16-18 X 1-3/4 ZP	71	3	265310	Y CONNECTOR - 1/8 DIA-PL
9	16	9179	SCREW - HHCS 5/16-18 X 2-1/4 ZP	72	2	265404	PLASTIC RIVET
10	4	9183	SCREW - HHCS 5/16-18 X 3-1/2 ZP	73	1	600881B	DISPLAY BOX - 5 WIN
11	14	9226	NUT - HELN 5/16-18 ZP	74	1	605056B	DISPLAY BOX - BACK
12	8	9227	NUT - HRLN 3/8-16 ZP	75	1	605428	GROUND CLAMP - DISPLAY
13	2	9231	NUT - HJN 3/4-10 ZP	76	1	953101	TUBING - .375 OD X .062 W-PE BLK
14	2	9250	SCREW - HHCS 5/8-18 X 1 1/4 ZP	77	1	953108	TUBING - 1/4 URETHANE BLK
15	2	9272	SCREW - CRPHTS-TF #6-32 X 1/2 SS	78	1	955300	STRIP - PROTECTOR-4 INCH
16	4	9279	SCREW - SBHTS-TF 5/16-18 X 3/4 ZP	79	2	962004	CON - 2MM-2-S
17	7	9285	SCREW - CRPHTS 10-24 X 3/4 ZP	80	4	962005	CON - MOD - P-4P-4C
18	6	9291	SCREW - CRPHTS 8 X 1/2 ZP	81	1	962016	CON - MOD-COUPLER-6-6
19	28	9353	WASHER - THIN-ACFT 0313 SS	82	4	962017	CON-MOD-P-6P-6C
20	6	9355	WASHER - FW-ACFT-3/8 SS	83	1	966701	WIRE - CABLE-4-26GA
21	2	9364	WASHER - ITLW 3/4 ZP	84	1	966702	WIRE - CABLE-6-26 GA
22	2	9366	WASHER - ITLW #6 ZP	85	1	990806	ASSY - PROCESSOR BOX
23	2	9389	WASHER - ITLW 5/16 ZP	86	2	995000	COLLAR - GRIP
24	4	105423	BUMPER - MOLDED GLIDE	87	2	995001	CAP - GRIP W HOLE
25	2	110830	ASSY - TB VALVE-DIG	88	2	995094	COVER - 144 CU IN TANK
26	4	110894	BEARING ASSY	89	2	995160	GRIP - MOLDED
27	1	110897	ASSY - QD-MALE	90	1	995300	DECAL - TB-PLUS
28	4	113040	SHOULDER SLEEVE - 1/2 X 1/2	91	1	995301	DECAL - TB-MINUS
29	2	115000	BUSHING - TANK	92	1	995308	DECAL - SEAT-POWER
30	2	115005	CLEVIS - CYLINDER-2-1/2	93	1	995324	DECAL - MADE IN THE USA
31	12	115051	BEARING - FLANGE-0.500 ID	94	1	995387	DECAL - SN-NO CERT MARKS
32	3	115054	PLUG - 2 IN SQ-KEISER	95	1	995418	BAG - 4 X 6 X 4MIL-ZIP LOCK
33	4	115067	CAP - Ø1 X 3/4	96	1	995615	PLACARD - ENG-POWER-BLK
34	1	115323	FILTER - IN LINE	97	1	995616	PLACARD - ENG-KEY-RED
35	2	115333	O-RING - .943 X .737 X .103				
36	3	115372	DECAL - KEISER LOGO-1 1/4" RED				
37	5	115404	PLUG - HOLE-1 DIA				
38	20	115423	TIE - 8 IN-PL BLK				
39	1	115429	PLASTIC TIE - 10" RED				
40	4	115450	WASHER - FW .88 X .39 X .07 NP				
41	4	115451	SCREW - SBHCS 3/8-16 X 1-1/4 NP				
42	2	130832	ASSY - EC-2.5 X 12				
43	1	130864	CUSHION - HEAD-CURVED				
44	1	130867	CUSHION - BACK-CURVED				
45	1	130870	CUSHION - SEAT-CURVED				
46	1	130933	WELDT - DISPLAY MT				
47	1	130934	WELDT - FRM-SEAT				
48	4	132181	TUBE - ROLLER				
49	8	132200	AXLE				
50	4	132201	AXLE - THREADED				
51	2	135005	SEAT RACK				
52	2	135006	SEAT RAIL				
53	4	135050	BEARING - FLANGE-1" ID				
54	4	135055	STEM BUMPER				
55	12	135060	ROLLER				
56	4	135076	PLASTIC BUMPER				
57	1	135306	DECAL - SEAT-1-10				
58	2	135422	RUBBER CRUTCH TIP #20 BLK				
59	1	160900	MAIN FRAME - 1632				
60	1	160901	ARM - L				
61	1	160902	ARM - R				
62	1	160903	ARM - LEVER-L				
63	1	160904	ARM - LEVER-R				



PRINTED ON: 2/9/2026

**KEISER**<sup>®</sup>

2470 South Cherry Ave. Phone: (559) 256-8000  
 Fresno, CA, USA 93706-5004 Fax: (559) 256-8100

THE INFORMATION DISCLOSED HEREIN WAS ORIGINATED BY AND IS THE PROPERTY OF KEISER CORP. AND ALL PATENT, PROPRIETARY, DESIGN, USE, SALE, MANUFACTURING, AND REPRODUCTION RIGHTS THERETO ARE RESERVED BY KEISER CORP.

DIMENSIONS ARE IN INCHES  
 DIMENSIONS IN [ ] ARE MILLIMETERS  
 BREAK SHARP EDGES .005-.015 [.10-.40]  
 MACHINED SURFACE FINISH IS  
 63 MICROINCHES [1.6 MICROMETERS]  
 DO NOT SCALE DRAWING

DRAWN BY: JPR DATE DRAWN: 10/13/25 CHECKED BY: LC DATE CHECKED: 2/5/26

MATERIAL: RAW MAT: MASS (Kg):

TITLE: A300 MILITARY PRESS - SA

SHEET 2 OF 2 SCALE: 1:10 DRAWING SIZE: B PART#: 1632XP-SA

REV	ECO	REVISION DESCRIPTION	BY	CKD	DATE
A	4488	REFERENCE OBS DRAWING REV C	JPR	LC	2/5/26