

COMMONLY SERVICED COMPONENTS

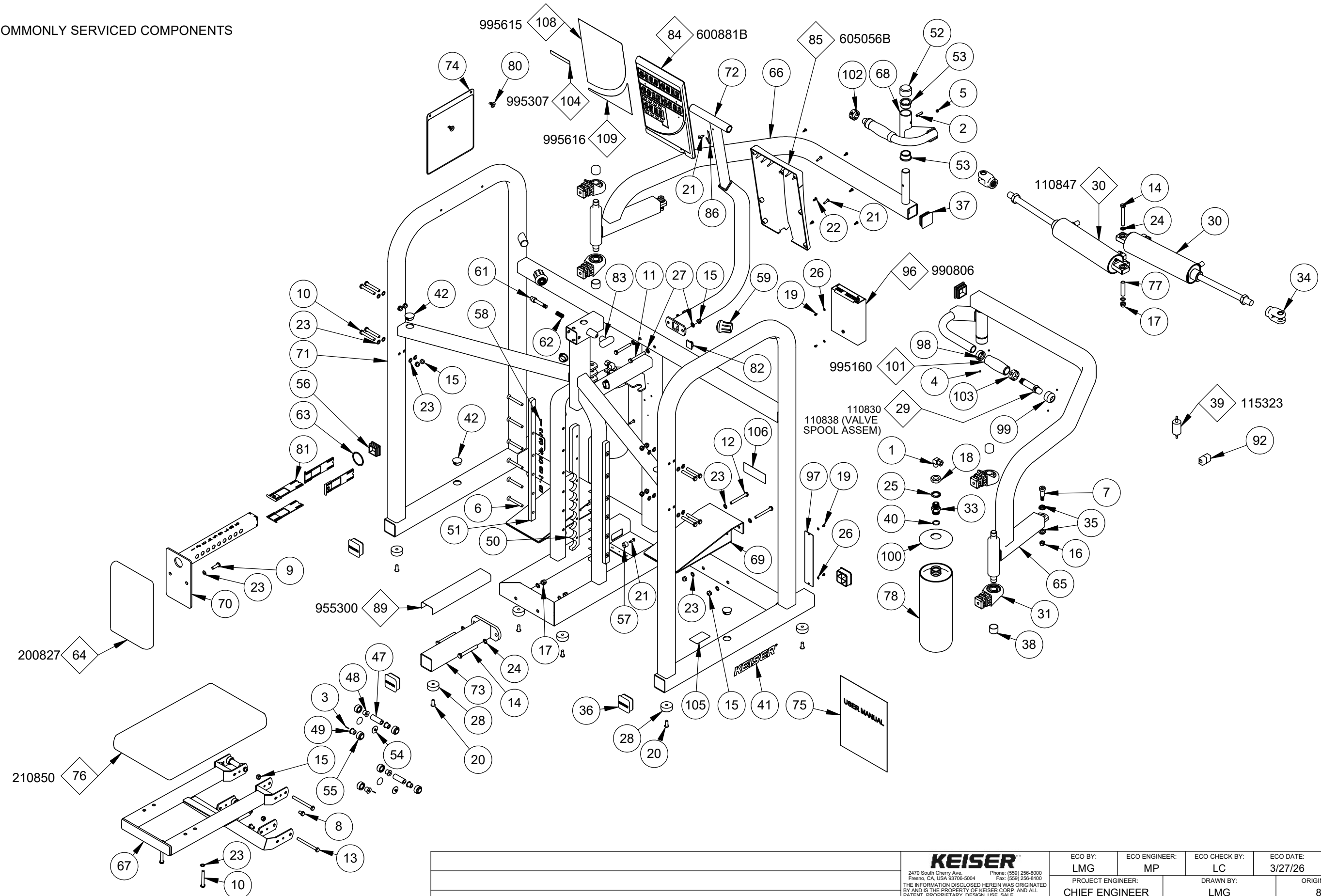

NOTE:
THIS DRAWING COVERS: 2035BP AND 2035SP

		KEISER <small>2470 South Cherry Ave. Fresno, CA USA 93705-5004 Phone: (559) 256-8000 Fax: (559) 256-8100</small>		ECO BY: LMG	ECO ENGINEER: MP	ECO CHECK BY: LC	ECO DATE: 3/27/26	ECO: 4495
		<small>THE INFORMATION DISCLOSED HEREIN WAS ORIGINATED BY AND IS THE PROPERTY OF KEISER CORP. AND ALL PATENT, PROPRIETARY DESIGN, USE, SALE, MANUFACTURING, AND REPRODUCTION RIGHTS THERE TO ARE RESERVED BY KEISER CORP.</small>		PROJECT ENGINEER: CHIEF ENGINEER		DRAWN BY: LMG		ORIGINATION DATE: 8/11/25
		<small>DIMENSIONS ARE IN INCHES DIMENSIONS IN [] ARE MILLIMETERS BREAK SHARP EDGES .005-.015 [.10-.40] MACHINED SURFACE FINISH IS 63 MICRONS [1.6 MICROMETERS]</small>		MATERIAL:				MATERIAL #:
REV: C	REFERENCE PRODUCTION DRAWING REV D	TITLE: A350 BIAXIAL UPPER BACK - SA				PART #: 2035XP-SA	REV: C	

SHEET: 1 OF 2 SIZE B SCALE 1:12 (DO NOT SCALE DRAWING) LAST SAVED: 3/27/2026

ITEM NO.	QTY.	PART NO.	TITLE	ITEM NO.	QTY.	PART NO.	TITLE
1	2	8153	CAF - ME-3/8 C X 1/4 M	61	1	172180	PLUNGER
2	2	9005	PIN-SPRING - 1/4 X 1	62	1	175500	SPRING - PLUNGER
3	4	9009	PIN-SPRING - 1/16 X 1/2	63	1	175502	SPRING RING - 1.750 ID
4	8	9014	SCREW - HSSS 8-32 X 1/8 SS	64	1	200827	CHEST CUSHION
5	2	9026	SCREW - HSSS 5/16-18 X 1/4 ZP	65	1	200918	WELDT - EX ARM-LT
6	12	9079	SCREW - SCSHCS 5/16-18 X 1 ZP	66	1	200919	WELDT - EX ARM-RT
7	2	9127	SCREW - SHSS 1/2 X 1 ZP	67	1	200920	SEAT - A250
8	4	9174	SCREW - HHCS 5/16-18 X 1/2 ZP	68	2	200921	WELDT - EXERCISE HANDLE
9	2	9176	SCREW - HHCS 5/16-18 X 1 ZP	69	2	200922	WELDT - FOOTPLATE
10	10	9179	SCREW - HHCS 5/16-18 X 2-1/4 ZP	70	1	200923	WELDT - SUPPORT-CHEST
11	2	9180	SCREW - HHCS 5/16-18 X 2-1/2 ZP	71	1	200933	FRAME - MAIN-BIAXIAL UPPER BACK-A400
12	4	9181	SCREW - HHCS 5/16-18 X 2-3/4 ZP	72	1	200926	WELDT - DISPLAY MT-350
13	4	9183	SCREW - HHCS 5/16-18 X 3-1/2 ZP	73	1	200927	WELDT - OUTRIGGER
14	3	9209	SCREW - HHCS 3/8-16 X 3 ZP	74	1	205417	PLACARD - A350 BIAXIAL UPPER BACK
15	18	9226	NUT - HELN 5/16-18 ZP	75	1	205500	MANUAL - USER-A350 BIAX UPPER BACK
16	2	9227	NUT - HRLN 3/8-16 ZP	76	1	210850	BACK CUSHION
17	3	9228	NUT - HELN 3/8-16 ZP	77	1	253040	TUBE - ROLLER
18	2	9231	NUT - HJN 3/4-10 ZP	78	2	255318	TANK - 144 CU IN
19	4	9255	SCREW - CRPHMS 6-32 X 1/4 ZP	79	3	265310	Y CONNECTOR - 1/8 DIA-PL
20	7	9279	SCREW - SBHTS-TF 5/16-18 X 3/4 ZP	80	2	265404	PLASTIC RIVET
21	7	9285	SCREW - CRPHTS 10-24 X 3/4 ZP	81	4	505068	BUSHING - 4 PIECE
22	6	9291	SCREW - CRPHTS 8 X 1/2 ZP	82	1	545055	ANCHOR - CABLE PL
23	28	9353	WASHER - THIN-ACFT 0313 SS	83	1	555059	KNOB - T-BLACK
24	6	9355	WASHER - FW-ACFT-3/8 SS	84	1	600881B	DISPLAY BOX - 5 WIN
25	2	9364	WASHER - ITLW 3/4 ZP	85	1	605056B	DISPLAY BOX - BACK
26	4	9366	WASHER - ITLW #6 ZP	86	1	605428	GROUND CLAMP - DISPLAY
27	4	9389	WASHER - ITLW 5/16 ZP	87	1	953101	TUBING - Ø3/8 OD X 1/16 W-PE BLK
28	7	105423	BUMPER - MOLDED GLIDE	88	1	953108	TUBING - 1/4 URETHANE BLK
29	2	110830	ASSY - TB VALVE-DIG	89	1	955300	STRIP - PROTECTOR-4 INCH
30	2	110847	ASSY - EC-2500 X 7000	90	2	962004	CON - 2MM-2-S
31	4	110894	BEARING - TUBE MT-0750 ID	91	6	962005	CON - MOD - P-4P-4C
32	1	110897	ASSY - QD-MALE	92	1	962016	CON - MOD-COUPLER-6-6
33	2	115000	BUSHING - TANK	93	4	962017	CON-MOD-P-6P-6C
34	2	115005	CLEVIS - CYLINDER-2500	94	1	966701	WIRE - CABLE-4-26 GA
35	4	115051	BEARING - FLANGE-0.500 ID	95	1	966702	WIRE - CABLE-6-26GA
36	5	115054	PLUG - 2 IN SQ-KEISER	96	1	990806	ASSY - PROCESSOR BOX
37	2	115059	CAP - 1-3/4 SQ	97	1	992075	PLATE - COVER-POWER ENTRY-WO HOLE
38	4	115067	CAP - Ø1 X 3/4	98	2	995000	COLLAR - GRIP
39	1	115323	FILTER - IN LINE	99	2	995001	CAP - GRIP W HOLE
40	2	115333	O-RING - .943 X .737 X .103	100	2	995094	COVER - 144 CU IN TANK
41	2	115372	DECAL - KEISER LOGO-1 1/4" RED	101	2	995160	GRIP - MOLDED
42	6	115404	PLUG - HOLE-1 DIA	102	1	995300	DECAL - TB-PLUS
43	21	115423	TIE - 8 IN-PL BLK	103	1	995301	DECAL - TB-MINUS
44	1	115429	PLASTIC TIE - 10" RED	104	1	995307	DECAL - SEAT, CHEST-POWER
45	2	115430	PLASTIC TIE - 4 INCHES-BLK	105	1	995324	DECAL - MADE IN THE USA
46	1	125420	PLASTIC TIE - 14.5 BLK	106	1	995385	DECAL - SN-STRENGTH-CE-UKCA-MDR
47	4	132181	TUBE - ROLLER	107	1	995418	BAG - 4 X 6 X 4MIL-ZIP LOCK
48	8	132200	AXLE	108	1	995615	PLACARD - ENG-POWER-BLK
49	4	132201	AXLE - THREADED	109	1	995616	PLACARD - ENG-KEY-RED
50	2	135005	SEAT RACK				
51	2	135006	SEAT RAIL				
52	2	135049	CAP - Ø1 ID				
53	4	135050	BEARING - FLANGE-1" ID				
54	4	135055	STEM BUMPER				
55	12	135060	ROLLER				
56	1	135061	1.5 SQ.INSRT GLD-RIBS				
57	4	135076	PLASTIC BUMPER				
58	1	135306	DECAL - SEAT-1-10				
59	2	135422	RUBBER CRUTCH TIP #20 BLK				
60	1	170891	ASSY - MUFFLER-LONG				

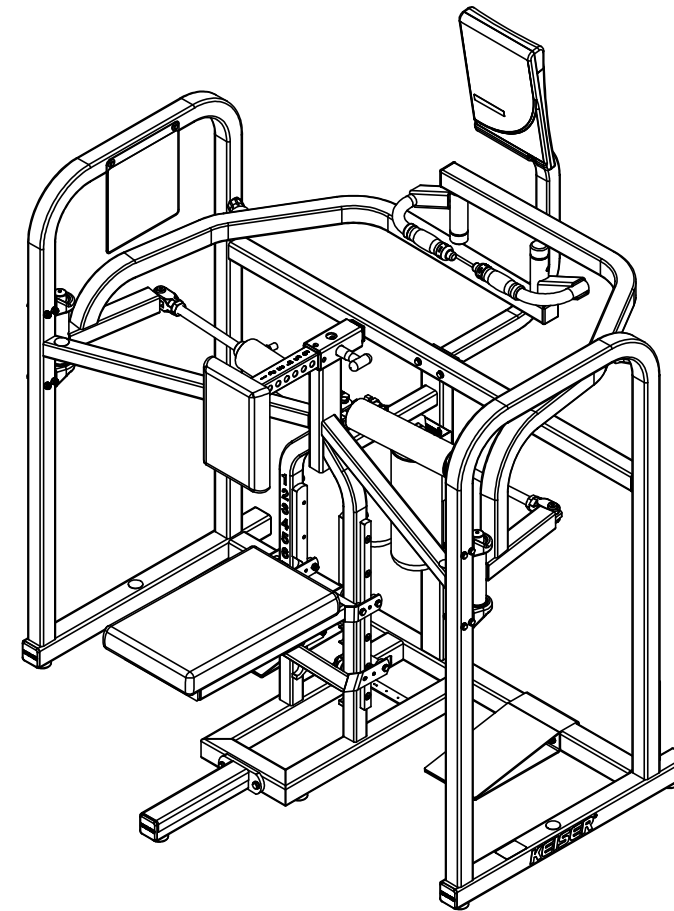

		ECO BY:	ECO ENGINEER:	ECO CHECK BY:	ECO DATE:	ECO:	
		LMG	MP	LC	3/27/26	4495	
		PROJECT ENGINEER:		DRAWN BY:		ORIGINATION DATE:	
		CHIEF ENGINEER		LMG		8/11/25	
		MATERIAL:				MATERIAL #:	
		TITLE:				PART #:	REV:
		A350 BIAXIAL UPPER BACK - SA				2035XP-SA	C
REV:	REFERENCE PRODUCTION DRAWING REV D						
C							

ITEM NO.	QTY.	PART NO.	TITLE	ITEM NO.	QTY.	PART NO.	TITLE
1	1	8079	CON - 3/8C X 1/4M	61	2	135422	RUBBER CRUTCH TIP #20 BLK
2	1	8101	TEE - UNION-3/8	62	1	155369	TANK - 300 CU IN-PAINTED
3	2	9005	PIN-SPRING - 1/4 X 1	63	1	170891	ASSY - MUFFLER-LONG
4	4	9009	PIN-SPRING - 1/16 X 1/2	64	1	172180	PLUNGER
5	8	9014	SCREW - HSSS 8-32 X 1/8 SS	65	1	175500	SPRING - PLUNGER
6	2	9026	SCREW - HSSS 5/16-18 X 1/4 ZP	66	1	175502	SPRING RING - 1.750 ID
7	12	9079	SCREW - SCSHCS 5/16-18 X 1 ZP	67	1	200827	CHEST CUSHION
8	2	9127	SCREW - SHSS 1/2 X 1 ZP	68	1	200918	WELDT - EX ARM-LT
9	4	9174	SCREW - HHCS 5/16-18 X 1/2 ZP	69	1	200919	WELDT - EX ARM-RT
10	2	9176	SCREW - HHCS 5/16-18 X 1 ZP	70	1	200920	SEAT - A250
11	10	9179	SCREW - HHCS 5/16-18 X 2-1/4 ZP	71	2	200921	WELDT - EXERCISE HANDLE
12	2	9180	SCREW - HHCS 5/16-18 X 2-1/2 ZP	72	2	200922	WELDT - FOOTPLATE
13	4	9181	SCREW - HHCS 5/16-18 X 2-3/4 ZP	73	1	200923	WELDT - SUPPORT-CHEST
14	4	9183	SCREW - HHCS 5/16-18 X 3-1/2 ZP	74	1	200924	WELDT - MAINFRAME
15	2	9201	SCREW - HHCS 3/8-16 X 1 ZP	75	1	200926	WELDT - DISPLAY MT-350
16	1	9209	SCREW - HHCS 3/8-16 X 3 ZP	76	1	200927	WELDT - OUTRIGGER
17	18	9226	NUT - HELN 5/16-18 ZP	77	1	205417	PLACARD - A350 BIAXIAL UPPER BACK
18	2	9227	NUT - HRLN 3/8-16 ZP	78	1	205500	MANUAL - USER - A350 BIAX UPPER BACK
19	3	9228	NUT - HELN 3/8-16 ZP	79	1	210850	BACK CUSHION
20	1	9231	NUT - HJN 3/4-10 ZP	80	1	253040	TUBE - ROLLER
21	2	9272	SCREW - CRPHTS-TF #6-32 X 1/2 SS	81	3	265310	Y CONNECTOR - 1/8 DIA-PL
22	7	9279	SCREW - SBHTS-TF 5/16-18 X 3/4 ZP	82	2	265404	PLASTIC RIVET
23	7	9285	SCREW - CRPHTS 10-24 X 3/4 ZP	83	4	505068	BUSHING - 4 PIECE
24	6	9291	SCREW - CRPHTS 8 X 1/2 ZP	84	1	545055	ANCHOR - CABLE PL
25	28	9353	WASHER - THIN-ACFT 0313 SS	85	1	555059	KNOB - T-BLACK
26	6	9355	WASHER - FW-ACFT-3/8 SS	86	1	600881X	DISPLAY BOX - 5 WIN
27	1	9364	WASHER - ITLW 3/4 ZP	87	1	605056	DISPLAY BOX - BACK
28	2	9366	WASHER - ITLW #6 ZP	88	1	605428	GROUND CLAMP - DISPLAY
29	4	9389	WASHER - ITLW 5/16 ZP	89	1	953101	TUBING - Ø3/8 OD X 1/16 W-PE BLK
30	7	105423	BUMPER - MOLDED GLIDE	90	1	953108	TUBING - 1/4 URETHANE BLK
31	2	110830	ASSY - TB VALVE-DIG	91	1	955300	STRIP - PROTECTOR-4 INCH
32	2	110847	ASSY - EC-2.5 X 7	92	2	962004	CON - 2MM-2-S
33	4	110894	BEARING ASSY	93	6	962005	CON - MOD - P-4P-4C
34	1	110897	ASSY - QD-MALE	94	1	962016	CON - MOD-COUPLER-6-6
35	1	115000	BUSHING - TANK	95	4	962017	CON-MOD-P-6P-6C
36	2	115005	CLEVIS - CYLINDER-2-1/2	96	1	966701	WIRE - CABLE-4-26 GA
37	4	115051	BEARING - FLANGE-0.500 ID	97	1	966702	WIRE - CABLE-6-26GA
38	5	115054	PLUG - 2 IN SQ-KEISER	98	1	990806	ASSY - PROCESSOR BOX
39	2	115059	CAP - 1-3/4 SQ	99	2	995000	COLLAR - GRIP
40	4	115067	CAP - Ø1 X 3/4	100	2	995001	CAP - GRIP W HOLE
41	1	115323	FILTER - IN LINE	101	2	995160	GRIP - MOLDED
42	1	115333	O-RING - .943 X .737 X .103	102	1	995300	DECAL - TB-PLUS
43	2	115372	DECAL - KEISER LOGO-1 1/4" RED	103	1	995301	DECAL - TB-MINUS
44	6	115404	PLUG - HOLE-1 DIA	104	1	995307	DECAL - SEAT, CHEST-POWER
45	27	115423	TIE - 8 IN-PL BLK	105	1	995324	DECAL - MADE IN THE USA
46	1	115429	PLASTIC TIE - 10" RED	106	1	995381	DECAL - SERIAL NUMBER - STRENGTH
47	2	115430	PLASTIC TIE - 3" BLK	107	1	995418	BAG - 4 X 6 X 4MIL-ZIP LOCK
48	1	125420	PLASTIC TIE - 14.5 BLK	108	1	995615	PLACARD - ENG-POWER-BLK
49	4	132181	TUBE - ROLLER	109	1	995616	PLACARD - ENG-KEY-RED
50	8	132200	AXLE				
51	4	132201	AXLE - THREADED				
52	2	135005	SEAT RACK				
53	2	135006	SEAT RAIL				
54	2	135049	CAP - Ø1 ID				
55	4	135050	BEARING - FLANGE-1" ID				
56	6	135055	STEM BUMPER				
57	12	135060	ROLLER				
58	1	135061	1.5 SQ.INSRT GLD-RIBS				
59	4	135076	PLASTIC BUMPER				
60	1	135306	DECAL - SEAT-1-10				

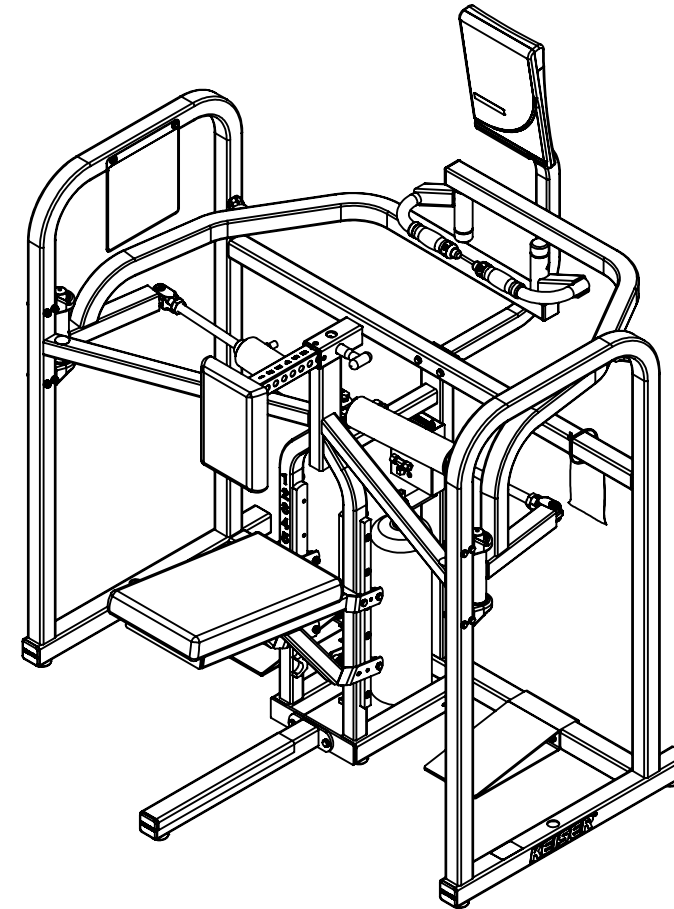

PRINTED ON: 3/20/2024

KEISER®

2470 South Cherry Ave. Phone: (559) 256-8000
 Fresno, CA, USA 93706-5004 Fax: (559) 256-8100

THE INFORMATION DISCLOSED HEREIN WAS ORIGINATED BY AND IS THE PROPERTY OF KEISER CORP. AND ALL PATENT, PROPRIETARY, DESIGN, USE, SALE, MANUFACTURING, AND REPRODUCTION RIGHTS THERETO ARE RESERVED BY KEISER CORP.

DIMENSIONS ARE IN INCHES
 DIMENSIONS IN [] ARE MILLIMETERS
 BREAK SHARP EDGES .005-.015 [.10-.40]
 MACHINED SURFACE FINISH IS
 63 MICROINCHES [1.6 MICROMETERS]
 DO NOT SCALE DRAWING

DRAWN BY: BJU DATE DRAWN: 10/13/20 CHECKED BY: LC DATE CHECKED: 1/22/21

MATERIAL: RAW MAT: MASS (Kg):

REV	ECO	REVISION DESCRIPTION	BY	CKD	DATE
B	4044	REFERENCE ECO MEMO FOR DETAILS	BJU	LC	7/15/22

TITLE: **A350 BIAXIAL UPPER BACK - SA**
 SHEET **2** OF **2** SCALE: **1:16** DRAWING SIZE: **B** PART#: **2035XP-SA**