

3331X4-SA

ITEM NO.	QTY.	PART NO.	TITLE	ITEM NO.	QTY.	PART NO.	TITLE
1	3	8043	CON - 3/16 BARB X 1/8 BARB	62	2	962071	CON - S-20-24 AWG-CRIMP-TIN
2	2	8044	CON - 8MM PTC X 1/4M NPT	63	1	962072	CON - 3MM-2-S
3	2	8301	BUSH - SPT-7/8 X 3/8	64	2	962073	CON - S-20-24 AWG-CRIMP-MOLEX
4	2	8352	NIPPLE - HN-3/8	65	2	962074	CON - MOD-P-8P-8C
5	2	8477	NIPPLE - LN-3/8 X 3-1/2	66	1	964506	FILTER - FERRITE-310 OHM
6	8	9014	SCREW - HSS 8-32 X 1/8 SS	67	1	966701	WIRE - CABLE-4-26 GA
7	4	9087	SCREW - CRFCHMS 6-32 X 1/4 SS	68	1	966712	WIRE - CABLE-2-22 GA
8	4	9098	SCREW - SHCS 1/4-20 X 1/2 ZP	69	1	966717	WIRE - CABLE-8-24 GA
9	4	9128	SCREW - SHSS 5/8 X 1-1/4 ZP	70	1	966748	WIRE - CABLE-4 CIRCUIT-MICROFIT-2M
10	4	9176	SCREW - HHCS 5/16-18 X 1 ZP	71	1	990851	DISPLAY MODULE - A400
11	8	9179	SCREW - HHCS 5/16-18 X 2-1/4 ZP	72	1	990853	VALVE BLOCK - A400
12	2	9181	SCREW - HHCS 5/16-18 X 2-3/4 ZP	73	2	990856	CYL - XDCR-4000 X 12000
13	10	9226	NUT - HELN 5/16-18 ZP	74	1	990862	KIT - INSTALLATION-A400
14	2	9230	NUT - HEJN 1/2-13 ZP	75	1	990879	MODULE - POWER ENTRY-MDR
15	2	9241	NUT - HELN 1/2-13 ZP	76	1	990881	CKT BRD - PROCESSOR-A400-W SOFTWARE
16	2	9246	NUT - HELN #10-32 ZP	77	1	992058	PLATE - DISPLAY BACK-A400
17	2	9254	SCREW - HHMS #10-24 X 1-1/4 ZP	78	1	992059	PLATE - COVER-PROC BOX
18	9	9255	SCREW - CRPHMS 6-32 X 1/4 ZP	79	1	992064	BOX - PROCESSOR-A400
19	12	9279	SCREW - SBHTS-TF 5/16-18 X 3/4 ZP	80	2	995000	COLLAR - GRIP
20	4	9308	SCREW - CRPHMS 8-32 X 1/2 ZP	81	2	995001	CAP - GRIP W HOLE
21	20	9353	WASHER - THIN-ACFT 0313 SS	82	2	995160	GRIP - MOLDED
22	9	9366	WASHER - ITLW #6 ZP	83	1	995300	DECAL - TB-PLUS
23	4	9389	WASHER - ITLW 5/16 ZP	84	1	995301	DECAL - TB-MINUS
24	2	9506	SCREW - SBHCS M6X1 X 10 ZP	85	1	995324	DECAL - MADE IN THE USA
25	1	105058	PLUG - DIA 1-CLEAR	86	1	995330	FILTER - IN LINE-8MM PTC
26	12	105423	BUMPER - MOLDED GLIDE	87	1	995418	BAG - 4 X 6 X 4MIL-ZIP LOCK
27	1	105443	DECAL - SN-STRENGTH-CE	88	2	995602	DECAL - KEISER LOGO-2" RED
28	2	110830	ASSY - TB VALVE-DIG				
29	4	110894	BEARING - TUBE MT-0750 ID				
30	2	115054	PLUG - 2 IN SQ-KEISER				
31	4	115056	BEARING - FLANGE-0.625 ID-SHORT				
32	4	115067	CAP - Ø1 X 3/4				
33	2	115318	MUFFLER - EXHAUST-3/8				
34	4	115404	PLUG - HOLE-1 DIA				
35	14	115423	TIE - 8 IN-PL BLK				
36	1	115429	PLASTIC TIE - 10" RED				
37	2	135056	CAP - 1.500 SQ-PL				
38	1	150851	FOOT PAD				
39	1	150941	DISPLAY MT - A400				
40	8	151170	EXTRA WEIGHT 1.5X6X21				
41	2	152050	STRAP - TANK				
42	2	154502	ELBOW - 3/8F-TAPPED-1/4 NPT				
43	2	155008	TEE - MUFFLER				
44	1	155300	DECAL - CAUTION BK INJURIES				
45	2	155369	TANK - 300 CU IN-PAINTED				
46	2	155407	TAPE - FOAM-3/4 W				
47	2	165421	STOP - EA-URETHANE				
48	1	170891	ASSY - MUFFLER-LONG				
49	4	265404	PLASTIC RIVET				
50	1	330800	EX ARM - L				
51	1	330801	EX ARM - R				
52	1	330900	FRAME - MAIN-A400				
53	1	332050	PLATE - COVER				
54	1	953098	TUBING - 8MM URETHANE-BLK				
55	1	953108	TUBING - 1/4 URETHANE BLK				
56	2	955307	SLEEVING - 3/8 TO 5/8-BLK				
57	2	962004	CON - 2MM-2-S				
58	2	962005	CON - MOD-P-4P-4C				
59	4	962006	CON - MOD-P-6P-4C				
60	2	962055	CON - 2MM-8-S				
61	1	962070	CON - 2.5MM-6-S				

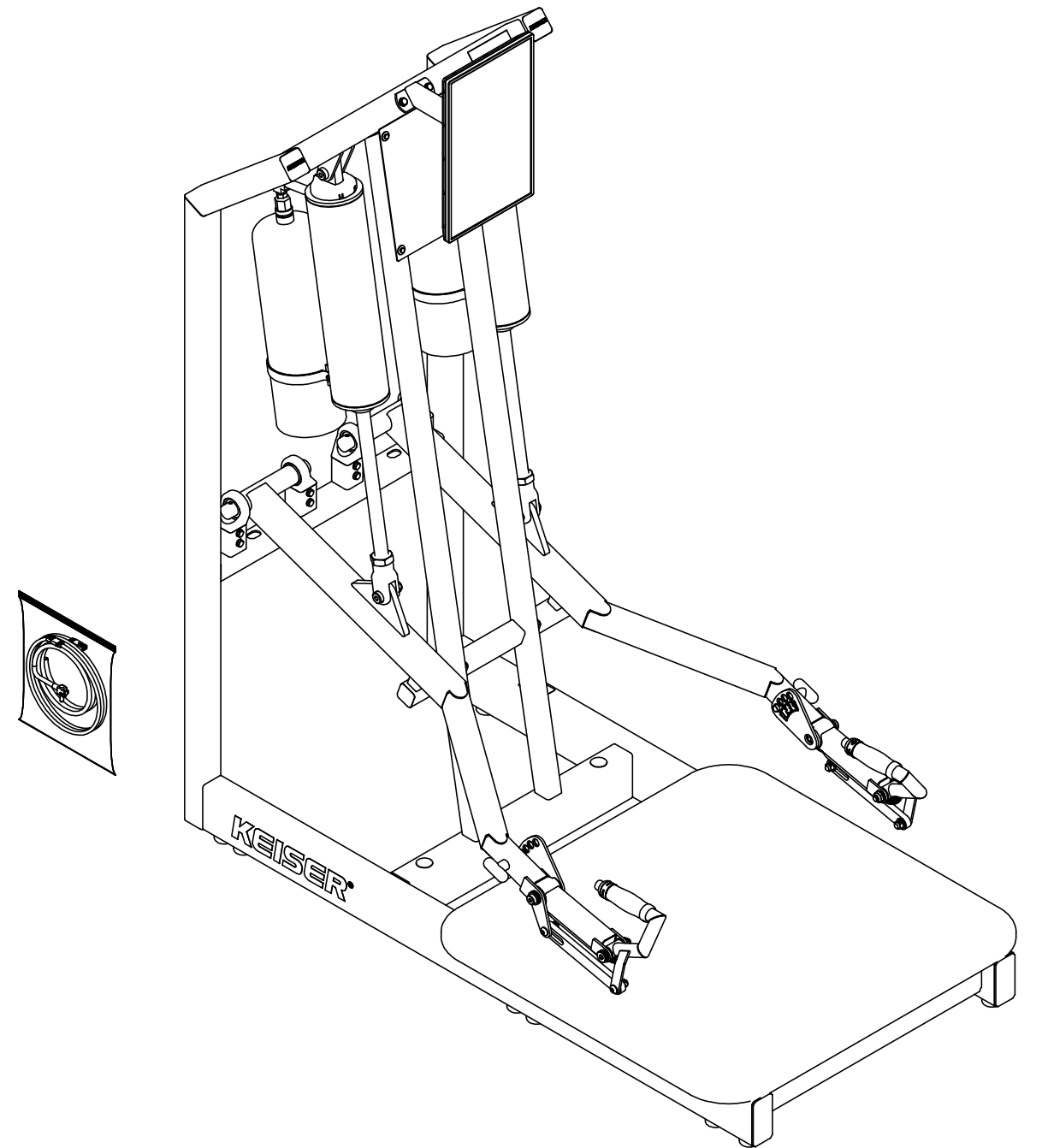

PRINTED ON: 3/11/2026

KEISER®

2470 South Cherry Ave. Phone: (559) 256-8000
 Fresno, CA, USA 93706-5004 Fax: (559) 256-8100

THE INFORMATION DISCLOSED HEREIN WAS ORIGINATED BY AND IS THE PROPERTY OF KEISER CORP. AND ALL PATENT, PROPRIETARY, DESIGN, USE, SALE, MANUFACTURING, AND REPRODUCTION RIGHTS THERETO ARE RESERVED BY KEISER CORP.

DIMENSIONS ARE IN INCHES
 DIMENSIONS IN [] ARE MILLIMETERS
 BREAK SHARP EDGES .005-.015 (.10-.40)
 MACHINED SURFACE FINISH IS
 63 MICROINCHES [1.6 MICROMETERS]
 DO NOT SCALE DRAWING

DRAWN BY: JC	DATE DRAWN: 3/28/25	CHECKED BY: QB	DATE CHECKED: 4/29/25
--------------	---------------------	----------------	-----------------------

MATERIAL: _____
 RAW MAT: _____
 MASS (Kg): _____

REV	ECO	REVISION DESCRIPTION	BY	CKD	DATE
B	4560	REFERENCE WM BOM REV F	AL	LC	3/11/26

TITLE: **A400 DEADLIFT - SA**
 SHEET **2** OF **2** SCALE: **1:12** DRAWING SIZE: **B** PART#: **3331X4-SA**

3331X4-SA

ITEM NO.	QTY.	PART NO.	TITLE	ITEM NO.	QTY.	PART NO.	TITLE
1	3	8043	CON - 3/16 BARB X 1/8 BARB	62	1	962072	CON - 3MM-2-S
2	2	8044	CON - 8MM PTC X 1/4M NPT	63	2	962073	CON - S-20-24 AWG-CRIMP-MOLEX
3	2	8301	BUSH - SPT-7/8 X 3/8	64	2	962074	CON - MOD-P-8P-8C
4	2	8352	NIPPLE - HN-3/8	65	1	964506	FILTER - FERRITE-310 OHM
5	2	8477	NIPPLE - LN-3/8 X 3-1/2	66	1	966701	WIRE - CABLE-4-26 GA
6	8	9014	SCREW - HSS 8-32 X 1/8 SS	67	1	966712	WIRE - CABLE-2-22 GA
7	4	9087	SCREW - CRFCHMS 6-32 X 1/4 SS	68	1	966717	WIRE - CABLE-8-24 GA
8	4	9098	SCREW - SHCS 1/4-20 X 1/2 ZP	69	1	966748	WIRE - CABLE-4 CIRCUIT-MICROFIT-2M
9	4	9128	SCREW - SHSS 5/8 X 1-1/4 ZP	70	1	990851	DISPLAY MODULE - A400
10	8	9179	SCREW - HHCS 5/16-18 X 2-1/4 ZP	71	1	990853	VALVE BLOCK - A400
11	2	9181	SCREW - HHCS 5/16-18 X 2-3/4 ZP	72	2	990856	CYL - XDCR-4000 X 12000
12	4	9186	SCREW - HHCS-5/16-18 X 4-1/2 ZP	73	1	990862	KIT - INSTALLATION-A400
13	10	9226	NUT - HELN 5/16-18 ZP	74	1	990879	MODULE - POWER ENTRY-MDR
14	4	9230	NUT - HELN 1/2-13 ZP	75	1	990881	CKT BRD - PROCESSOR-A400-W SOFTWARE
15	2	9246	NUT - HELN #10-32 ZP	76	1	992058	PLATE - DISPLAY BACK-A400
16	2	9254	SCREW - HHMS #10-24 X 1-1/4 ZP	77	1	992059	PLATE - COVER-PROC BOX
17	9	9255	SCREW - CRPHMS 6-32 X 1/4 ZP	78	1	992064	BOX - PROCESSOR-A400
18	12	9279	SCREW - SBHTS-TF 5/16-18 X 3/4 ZP	79	2	995000	COLLAR - GRIP
19	4	9308	SCREW - CRPHMS 8-32 X 1/2 ZP	80	2	995001	CAP - GRIP W HOLE
20	20	9353	WASHER - THIN-ACFT 0313 SS	81	2	995160	GRIP - MOLDED
21	9	9366	WASHER - ITLW #6 ZP	82	1	995300	DECAL - TB-PLUS
22	4	9389	WASHER - ITLW 5/16 ZP	83	1	995301	DECAL - TB-MINUS
23	2	9506	SCREW - SBHCS M6X1 X 10 ZP	84	1	995324	DECAL - MADE IN THE USA
24	1	105058	PLUG - DIA 1-CLEAR	85	1	995330	FILTER - IN LINE-8MM PTC
25	12	105423	BUMPER - MOLDED GLIDE	86	1	995418	BAG - 4 X 6 X 4MIL-ZIP LOCK
26	1	105443	DECAL - SN-STRENGTH-CE	87	2	995602	DECAL - KEISER LOGO-2" RED
27	2	110830	ASSY - TB VALVE-DIG				
28	4	110894	BEARING ASSY				
29	2	115054	PLUG - 2 IN SQ-KEISER				
30	4	115056	BEARING - FLANGE-0.625 ID-SHORT				
31	4	115067	CAP - Ø1 X 3/4				
32	2	115318	MUFFLER - EXHAUST-3/8				
33	4	115404	PLUG - HOLE-1 DIA				
34	14	115423	TIE - 8 IN-PL BLK				
35	1	115429	PLASTIC TIE - 10" RED				
36	2	135056	CAP - 1.500 SQ-PL				
37	1	150851	ASSY - FOOT PAD				
38	1	150941	DISPLAY MT - A400				
39	8	151170	EXTRA WEIGHT 1.5X6X21				
40	2	152050	STRAP - TANK				
41	2	154502	ELBOW - 3/8F-TAPPED-1/4 NPT				
42	2	155008	TEE - MUFFLER				
43	1	155300	DECAL - CAUTION BK INJURIES				
44	2	155369	TANK - 300 CU IN-PAINTED				
45	2	155407	TAPE - FOAM-3/4 W				
46	2	165421	STOP - EA-URETHANE				
47	1	170891	ASSY - MUFFLER-LONG				
48	4	265404	PLASTIC RIVET				
49	1	330800	EX ARM - L				
50	1	330801	EX ARM - R				
51	1	330900	FRAME - MAIN-A400				
52	1	332050	PLATE - COVER				
53	1	953098	TUBING - 8MM URETHANE-BLK				
54	1	953108	TUBING - 1/4 URETHANE BLK				
55	2	955307	SLEEVING - 3/8 TO 5/8-BLK				
56	2	962004	CON - 2MM-2-S				
57	2	962005	CON - MOD-P-4P-4C				
58	4	962006	CON - MOD-P-6P-4C				
59	2	962055	CON - 2MM-8-S				
60	1	962070	CON - 2.5MM-6-S				
61	2	962071	CON - S-20-24 AWG-CRIMP-TIN				

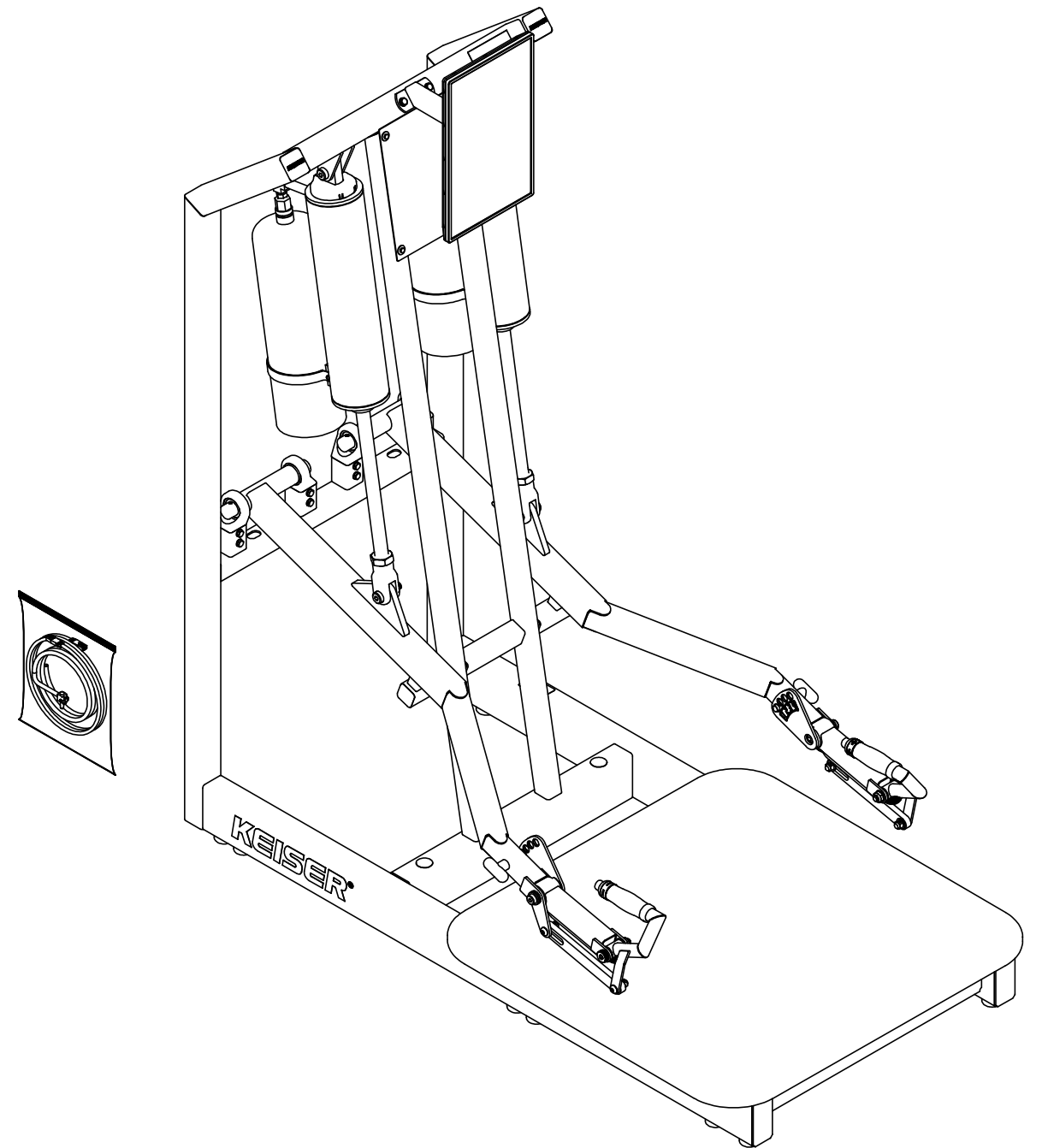

PRINTED ON: 4/30/2025

KEISER

2470 South Cherry Ave. Phone: (559) 256-8000
 Fresno, CA, USA 93706-5004 Fax: (559) 256-8100

THE INFORMATION DISCLOSED HEREIN WAS ORIGINATED BY AND IS THE PROPERTY OF KEISER CORP. AND ALL PATENT, PROPRIETARY, DESIGN, USE, SALE, MANUFACTURING, AND REPRODUCTION RIGHTS THERETO ARE RESERVED BY KEISER CORP.

DIMENSIONS ARE IN INCHES
 DIMENSIONS IN [] ARE MILLIMETERS
 BREAK SHARP EDGES .005-.015 [.10-.40]
 MACHINED SURFACE FINISH IS
 63 MICROINCHES [1.6 MICROMETERS]
 DO NOT SCALE DRAWING

DRAWN BY: JC DATE DRAWN: 3/28/25 CHECKED BY: QB DATE CHECKED: 4/29/25

MATERIAL: RAW MAT: MASS (Kg):

REV	ECO	REVISION DESCRIPTION	BY	CKD	DATE
A	4406	RFP	JC	LC	4/30/25

TITLE: **A400 DEADLIFT - SA**
 SHEET **2** OF **2** SCALE: **1:12** DRAWING SIZE: **B** PART#: **3331X4-SA**