

KEISER®

STRENGTH | CARDIO | FUNCTIONAL



M SERIES

M7i TOTAL BODY WHEELCHAIR STEPPER

MODELS: 005200B, 005200X

INSTALLATION AND OPERATION MANUAL

CONTENTS

03 – GENERAL INFORMATION

- 03_INTRODUCTION
- 03_REGISTER YOUR PURCHASE
- 03_RECORD YOUR SERIAL NUMBER

04 – IMPORTANT SAFETY INFORMATION

- 05_CONVENTIONS USED
- 06_SAFETY AND NOTIFICATION LABELS
- 07_CONTRAINDICATIONS

08 – TECHNICAL SPECIFICATIONS

- 08_EQUIPMENT SPECIFICATIONS
- 08_POWER SUPPLY

09 – ASSEMBLY AND PLACEMENT

11 – SET UP AND OPERATION

- 11_PRODUCT OVERVIEW
- 12_PROPER OPERATION CHECK
- 13_LEVELER FOOT
- 13_RESISTANCE LEVER
- 13_EMERGENCY BRAKE
- 13_FOOTSTRAPS
- 14_ADJUSTMENT KNOBS
- 14_RECOILER SAFETY STRAPS
- 14_ACCESSORIES

15 – COMPUTER DISPLAY

- 15_OVERVIEW
- 15_DISPLAY FEATURES
- 17_HOW TO EDIT THE MACHINE ID

18 – HOW TO EXERCISE ON THE M7i

- 18_BIOMECHANICAL POSITION
- 19_EXERCISE GUIDELINE
- 19_EXERCISE POSITIONS

20 – MAINTENANCE

- 20_PREVENTATIVE MAINTENANCE SCHEDULE
- 21_COMPUTER BATTERY REPLACEMENT
- 21_STORAGE
- 21_M SERIES CALIBRATION

22 – REGULATORY AND COMPLIANCE NOTICES

- 22_SAFETY NOTIFICATIONS
- 23_ELECTROMAGNETIC COMPATIBILITY (EMC)
- 23_US FCC COMPLIANCE STATEMENT
- 23_DISPOSAL

24 – WARRANTY STATEMENT

Keiser, the Keiser logo, and other trademarks associated with Keiser products referred to in this publication are trademarks of Keiser Corporation. © Copyright 2023, Keiser Corporation. All rights reserved.

Distribution and copying of this document, use and communication of its contents is not permitted without written authorization from Keiser Corporation. The content of this document is furnished for informational use only, may be subject to change without notice, and should not be construed as a commitment by Keiser Corporation. Every effort has been made to ensure that the information in this manual is accurate. Keiser Corporation is not responsible for printing or clerical errors.

GENERAL INFORMATION

INTRODUCTION

Congratulations on the purchase of your new Keiser M7i Total Body Wheelchair Stepper and welcome to the Keiser family. Your new resistance system is a revolutionary way to exercise providing a smoother, quieter, and more predictable workout. We commend you on your decision to work toward your health and wellness goals. For your safety, and to ensure the best experience and maximum gains, it is critical that you read and understand this manual before you begin using the M7i. If you have any questions regarding M7i installation or operation after reading this manual, our Keiser Customer Support team will be happy to assist by telephone at 1559 256 8000 or via live chat keiser.com/support (Monday–Friday, 7 am to 5:30 pm Pacific Standard Time), or by email at service@keiser.com.

Yours in Health,
Keiser Corporation

REGISTER YOUR PURCHASE

Register your M7i to stay informed of safety notifications and for faster, more accurate warranty service.

Scan the QR Code to the right to access the interactive online warranty registration form or visit:

<https://www.keiser.com/forms/warrantyregistration>



SCAN

RECORD YOUR SERIAL NUMBER

Please take a moment at this time to record the serial number in the space provided below.

Serial No.: _____

Serial Number Information	
A	Manufacturer name, logo, and address
B	Country of manufacture
C	Patent information notification
D	WEEE Directive mark
E	CE mark
F	TÜV SÜD mark
G	Unique Device Identification (UDI)
H	ISO Accuracy and Usage Classes
I	FCC Identifier
J	Maximum User Weight Limit (chair-equipped model)
K	Canadian IC Identifier
L	Directive and standards compliance
M	UK Responsible Person
N	European Authorized Representative
O	Serial number and date of manufacture
P	Model number and product description
Q	UK Conformity Assessed mark

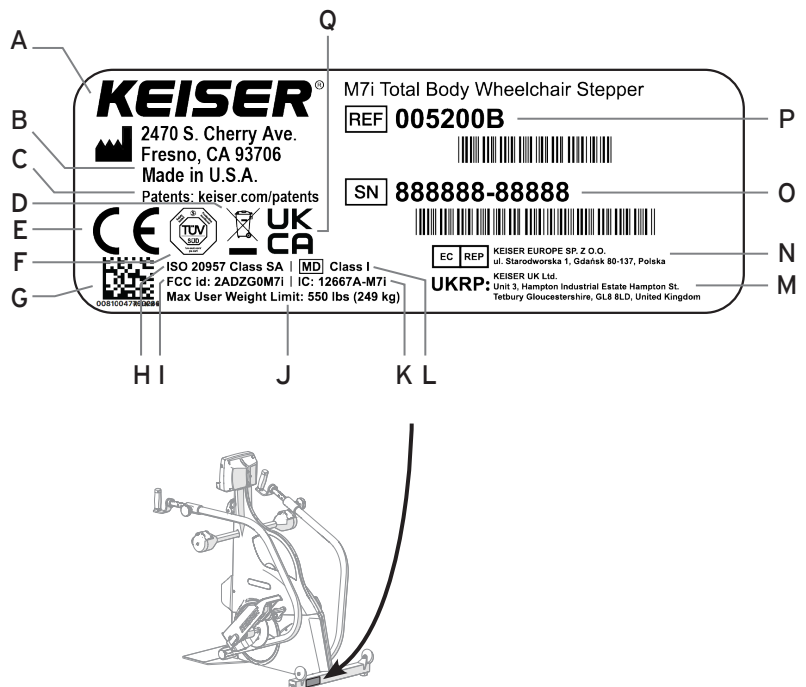

Marking plate illustration is for reference only. Refer to the marking plate attached to the equipment for specific product information.

Figure 1. Serial Number Location and Information

IMPORTANT SAFETY INFORMATION

It is the sole responsibility of the purchaser of Keiser Corporation equipment to instruct all individuals, whether they are the end-user or supervising personnel, on proper usage of the equipment. Keiser Corporation recommends that all users of its equipment be informed of the following information before use.





1.  Read these instructions. Keep these instructions.
2. Heed all warnings. Follow all instructions.
3. Use the M7i Total Body Wheelchair Stepper (herein referred to as "M7i") for its intended purpose as described in this manual. Do not use attachments that have not been recommended by the manufacturer.
4. Intended use of the M7i is for physical activity or Physiotherapy (sometimes referred to as physical therapy).
5. The M7i is intended for individuals aiming to maintain and restore maximum movement and functional ability throughout their lifespan, including circumstances where movement and function are limited by aging, injury, pain, disease, disorders, conditions, or environmental factors, especially in case of using the M7i in physical therapy.
6. Maximum user weight limit: 550 lbs (249 kg). User height requirement: 48 in (1,219 mm) or taller. Arm reach minimum requirement: 12 in (305 mm).
7. Consult your physician before beginning any exercise program, especially if you suffer from, have been diagnosed with, or have a family history of heart disease, respiratory disease, diabetes, high blood pressure, elevated cholesterol, arthritis, or any other diseases or physical complaints. Do not use the M7i until you have been cleared by your physician. Ensure that your physician is aware of any/all medication(s) you are taking.
8. Heart rate monitoring systems may be inaccurate. Over exercising may result in serious injury or death. If you feel faint, stop exercising immediately and consult your physician.
9. The M7i is intended for use in training areas of organizations where access and control is specifically regulated by a person responsible for determining the suitability of use and maintenance.
10. Supervision by a spotter is required if the user has a disability or medical condition.
11. Always attempt exercises for the first time with the assistance of a spotter and be aware of the potential for the wheelchair or mobility device to tip over in any direction.
12. Spotters must read and understand these safety instructions and should become familiar with the M7i prior to acting as a spotter/supervisor.
13. Wear proper shoes. Dress shoes, sandals, slippers, or bare feet are not suitable for use on the M7i. Quality athletic shoes are recommended to avoid leg fatigue. Do not wear clothing that might catch on any M7i moving parts.
14. Distractions, such as watching television, reading, using a computer device, or talking on the telephone while using the M7i affect the ability of the user to safely exercise on the M7i. Pay attention to and focus on your exercise while using the M7i.
15. Routinely check and pay special attention to components most susceptible to wear. Refer to the "Preventative Maintenance Schedule" (page 20) for further instruction.
16. Replace damaged, worn, or broken parts immediately and/or keep the M7i out of use until repaired.
17. Only use replacement parts recommended by Keiser Corporation. Attempting to repair or replace any damaged, worn, or broken parts on your own is not recommended. A Keiser certified technician should be consulted.
18. Proper biomechanical positioning is necessary to achieve a safe, comfortable, and effective workout. Proper leg and arm reach must always be maintained during every workout. Refer to the "Biomechanical Position" section (page 18) for further instruction and safety information.
19. As wheelchairs (manual or powered) vary, so will the means to stabilize them during exercise. Please take stability into consideration before exercise. This will help to prevent inadvertent movement or tip hazard during exercise.
20. Recoiler Safety Straps help increase wheelchair stability and must be used at all times during exercise. Use of the M7i without the Recoiler Safety Straps securely fastened may result in serious injury. Never place Recoiler Safety Strap Hooks below seat level. Refer to the "Recoiler Safety Straps" section (page 14) for detailed user instructions.
21. Sudden release of Recoiler Safety Straps in the unlocked position will snap back uncontrollably and could result in serious injury or damage to the M7i. Always check to ensure the Lock Levers are in the locked position during use.
22. The M7i is NOT designed with a freewheel, but a fixed gear system. The Handles are attached to the Crank Arms by linked components; these cannot be disengaged. When the Flywheel is in motion, the Footpads—including the Handles—will also be in motion. For this reason, never remove your feet from the Footpads while the Flywheel is in motion as serious user injury may occur. Never take your hands off the Handles while the Flywheel is in motion.
23. It is recommended that the M7i is pedaled in a forward rotation.
24. The Resistance Lever also functions as an Emergency Brake, allowing you to safely slow or stop the motion of the Flywheel. Move the Resistance Lever forward to slow the motion of the Flywheel. Move the Resistance Lever to the most forward position to engage the Emergency Brake.

IMPORTANT SAFETY INFORMATION

25. Do not make adjustments during exercise. Use the Handles or the Resistance Lever to slowly bring all motion to a controlled stop prior to making adjustments.
26. Before dismounting the M7i, push the Resistance Lever to the most forward position to engage the Emergency Brake. Wait until the Footpads and Handles come to a complete stop before dismounting.
27. Individuals with limited lower body control should always secure their feet with Foot Straps when operating the M7i. Swivel the Foot Strap to the upright position. Place your foot under the Foot Strap and onto the Footpad with your heel resting against the rear wall of the Footpad. Pull the Foot Strap end up and away from your foot to tighten the Foot Strap to your foot. Press the hook and loop surfaces firmly together to fasten. Ensure the Foot Strap is snug to fit without causing discomfort. Always wait for the M7i to come to a complete stop before attempting to adjust the Foot Straps.
28. Independent Footpad or Handle movements at high speeds for extended time periods are considered advanced techniques and should only be performed when the user has reached an advanced level, or under supervision by a person that has reached an advanced level.
29. The M7i is not a toy. Children shall not play with the M7i. Children under 14 years old should not use the M7i. Keep children and pets clear from the M7i at all times, especially while in use. Cleaning and user maintenance shall not be performed by children.
30. The M7i can be used by children age 14 years and above. Persons with mental disabilities, reduced physical, mental, or sensory capabilities, or lack of experience or knowledge should not use the M7i without constant supervision by a spotter/supervisor.
31. Ensure that all Recoiler Safety Straps and Foot Straps are secure and do not obstruct user movement and are not left hanging loose or unfastened so as to come in contact and interfere with the user or the M7i during operation.
32. The M7i should not be positioned in direct sunlight, in areas of extreme temperature and humidity, or where the M7i may be splashed with water or fluids. The M7i is intended for indoor use only.
33. The minimum amount of free area around the M7i is 36 inches (914 mm) on all sides. Refer to the "Training Space" section (page 10) for further placement direction.
34. The M7i is suited for both home and commercial use. To ensure your safety and to help prevent damage to the M7i, read all instructions before operating. Seek professional installation technicians if you are not able to safely perform the work necessary to unpack, assemble, and set the M7i in a desired exercise location.
35. Failure to perform the "Proper Operation Check" (page 12) prior to normal use of the M7i will void your warranty and could result in serious injury.
36. The use of any exercise equipment, including, without limitation, Keiser's strength training equipment in which resistance can be changed at anytime during the repetition, and any fixed gear bike, including, without limitation, the Keiser M7i Total Body Wheelchair Stepper, without proper instruction and supervision violates the terms of the agreement for purchase of such products. The ability to add resistance anytime during a repetition, including, without limitation, the ability to do a heavy negative may be dangerous, especially for anyone that does not recognize or respect the potential danger. The inability to stop pedaling on a fixed gear machine before the flywheel stops may also be dangerous to anyone riding, especially anyone that does not recognize or respect the potential danger.
37. Users, agents, and/or anyone directing the use of the M7i shall determine the suitability of the M7i for its intended use, and said parties are specifically put on notice that they shall assume all risk and liability in connection herewith.
38. If you have any questions regarding M7i installation or operation after reading this manual, contact Keiser Customer Support:
 -  1 559 256 8000
 -  service@keiser.com
 -  keiser.com/support
Telephone and Live Chat
Monday–Friday 7 am to 5:30 pm PST

CONVENTIONS USED

This Installation Instruction contains the following marks:

-  **WARNING:** Indicates a hazardous situation that, if not avoided, could result in death or serious injury.
-  **CAUTION:** Indicates a hazardous situation that, if not avoided, could result in minor or moderate injury.
-  **TWO-PERSON PROCEDURE:** Indicates help is required to safely and successfully complete installation.
-  **IMPORTANT:** Indicates information considered critical, but not hazard-related.



WARNING: Incorrect or excessive exercise may cause injury. If you experience any kind of pain, including but not limited to chest pains, nausea, dizziness, or shortness of breath, stop exercising immediately and consult your physician before continuing.

IMPORTANT SAFETY INFORMATION

SAFETY AND NOTIFICATION LABELS

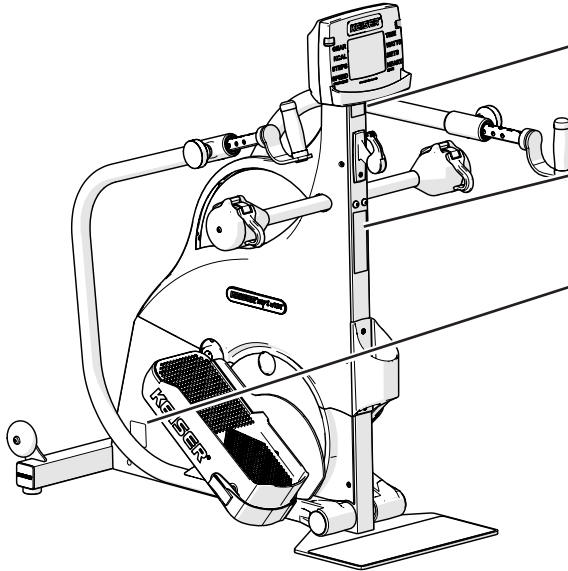

⚠ WARNING
Heart rate monitoring systems may be inaccurate. Over exercise may result in serious injury or death. If you feel faint stop exercising immediately.
555376

⚠ WARNING

CRUSH HAZARD
Keep Feet Clear
525375

⚠ WARNING
 Read the User Manual, follow all instructions prior to use. Ensure proper instruction is attained prior to using this machine.
IMPROPER USE OF THIS MACHINE CAN RESULT IN SERIOUS INJURY.

- Consult a physician prior to use and stop if you feel faint, dizzy, or exhausted.
- Refer to User Manual for additional warnings and safety information.
- This machine must be used in a supervised environment.
- Keep children away.
- Keep body, clothing, and accessories clear from all moving parts.
- Inspect machine prior to use. Immediately report worn, loose, or damaged parts and refrain from using the machine.
- Always ride in control. Stop in a controlled manner as flywheel momentum will keep handles and footpads moving.
- Do not attempt to dismount the machine or remove hands from handles or remove feet from footpads until footpads have come to a complete stop.
- Maximum user weight limit: 550 lbs (249 kg)

525376

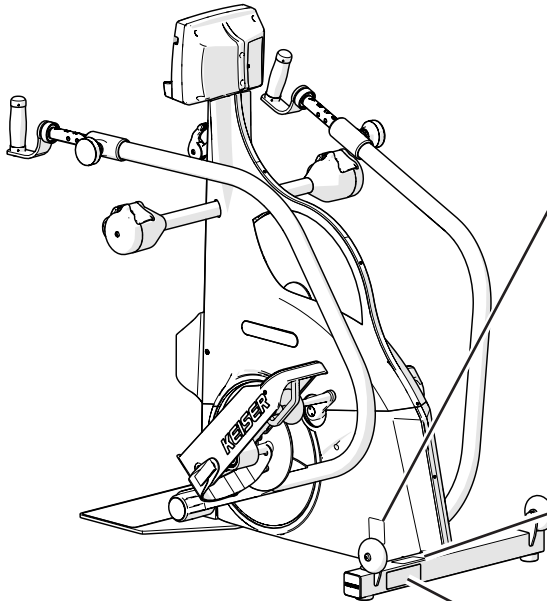

⚠ WARNING

CRUSH HAZARD
Keep Feet Clear
525375



KEISER® M7i Total Body Wheelchair Stepper
2470 S. Cherry Ave.
Fresno, CA 93706
Made in U.S.A.
Patents: keiser.com/patents

REF **005200B**

SN **888888-88888**

ISO 20957 Class SA | MDI Class I
FCC Id: 2ADZG0M7i | IC: 12667A-M7i
Max User Weight Limit: 550 lbs (249 kg)

KEISER EUROPE SP. Z O.O.
ul. Staroworska 1, Gdansk 80-137, Polska
KEISER UK Ltd
Unit 3, Hampton Industrial Estate Hampton St.
Tebury Gloucestershire, GL8 8LD, United Kingdom

Maintain safety and serial number labels. Do not remove labels for any reason. They contain important information. If unreadable or missing, contact Keiser Corporation for a replacement (see back cover for contact information).

IMPORTANT SAFETY INFORMATION

CONTRAINDICATIONS

There are a number of contraindications in the context of the relevant fields of the M7i use. In rehabilitation, only the medical staff can determine the form and extent of therapy. Medications can have an influence on the rehabilitation (e.g. neuroleptics, benzodiazepines, barbiturates, anti-epileptics, etc.). In the following cases, M7i training may only be carried out after consultation with a doctor:

- Pregnancy
- Acute thrombosis
- Fresh wounds (e.g. after surgery)
- Artificial joints or prosthetics
- Bone fractures
- Spinal disc damage
- Traumatic injury to the spine
- Diabetes
- Epilepsy
- Inflammation
- Acute migraine headache
- Chronic illnesses
- Cancer
- Acute myocardial infarction or unstable angina pectoris (determined by a stress test)
- Cardiovascular diseases e.g. severe high blood pressure at rest, carditis, congestive heart failure, severe valvular heart disease, dangerous heart arrhythmias at rest, or aortic aneurysm

If the patient is experiencing acute illness, febrile condition (i.e. fever), or newly occurring pain, this represents an absolute contraindication for physical stress. In such situations, it is necessary to postpone training until the patient's health has improved sufficiently.

In some situations (especially in patients with coronary heart disease or lung disease) overstraining can lead to an acute intensification of the patient's symptoms. In such situations, an exercise ECG is essential and training is only possible under medical supervision.

The use of the automated operation (pulse automatic, preset programs, external control via computer or other device) is prohibited, unless the strain was authorized by a physician in accordance with the patient's capacity/health.

For applications in endurance training, diagnostics and performance testing of patients, performance diagnostics, and stress tests, the same contraindications apply (among others) as with all physical stress. If there is doubt, it is important that a physician be consulted before using the M7i.

TECHNICAL SPECIFICATIONS

EQUIPMENT SPECIFICATIONS

Model No.	Device Label (Short Description)	Device Full Description
005200B	M7i TOTAL BODY WHLCHAIR STEPPER-BLK	M7i Total Body Wheelchair Stepper, Black (color)
005200X	M7i TOTAL BODY WHLCHAIR STEPPER-SPC	M7i Total Body Wheelchair Stepper, Special (color)

Dimensions (all models):

Height	Depth	Width	Weight
44 in (1,118 mm)	38.5 in (978 mm)	28 in (711 mm)	142 lbs (65 kg)

- User height requirement: 48 in (1,219 mm) or taller
- Arm reach minimum requirement: 12 in (305 mm)

The Keiser M7i Total Body Wheelchair Stepper is categorized per ISO/EN 20957-1 as Accuracy Class A (High Accuracy) and Usage Class S (Studio, commercial use) product for use in a controlled environment such as sports or fitness facilities under the supervision of a trainer.

POWER SUPPLY

Power: Quantity 2, 1.5V D Alkaline Batteries
(Keiser PN 966500)

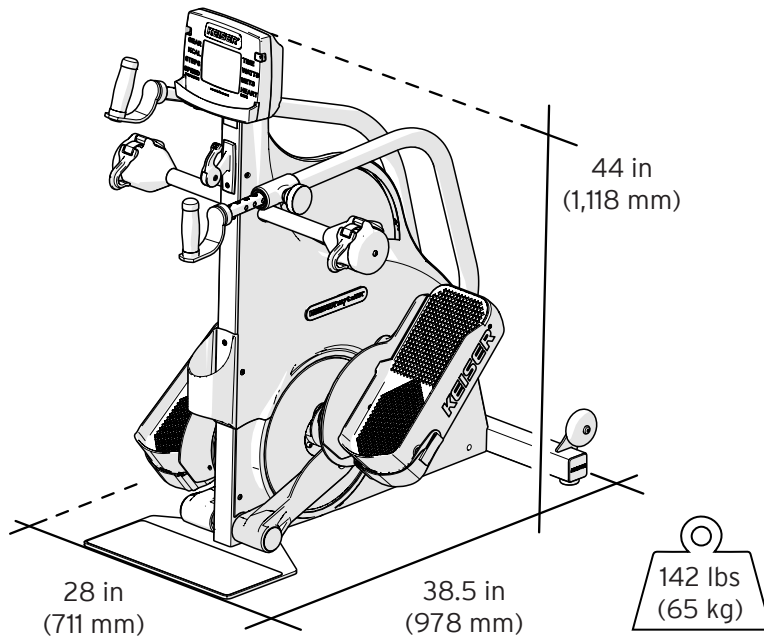

Figure 2. Equipment Specifications

ASSEMBLY AND PLACEMENT

TWO-PERSON PROCEDURE: Due to the size and weight of the equipment, help is required to safely and successfully complete installation.

Tools and Materials Required



Safety Blade



Scissors



5 mm Allen Wrench

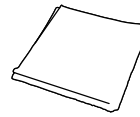

Dry Soft Cloth or Towel

Unpacking

Open the shipping container by cutting the box along the bottom; cut all shipping straps to release the equipment from the container. NOTE: Carefully remove all parts from the box and check for any damage or missing parts (see "Parts List," below). If parts are damaged or missing, contact your local dealer, distributor, or Keiser Customer Support by telephone at 1 559 256 8000.

Parts List

	Description	Qty	Keiser Part Number
1	M8 x 1.25 x 70 mm SBH Cap Screw	2	9543
2	Washer	2	9369
3	Left Recoiler Assembly	1	520805
4	Right Recoiler Assembly	1	520806

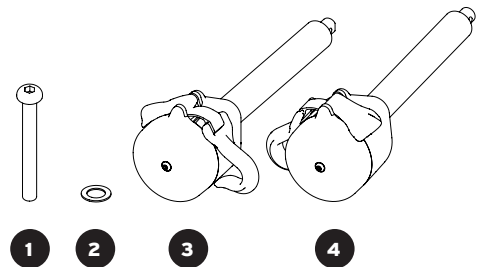

Figure 3. Parts List (images not to scale)

Recoilers Installation

Refer to Figure 4 and follow the instructions below:

1. Remove the two M8 screws and washers from the Main Frame using a 5 mm Allen Wrench.
2. Insert the Left and Right Recoiler shaft into the M7i Main Frame until it stops.
3. With all screw holes aligned, install the Recoilers to the Main Frame with one M8 screw with washer per side using a 5 mm Allen Wrench.

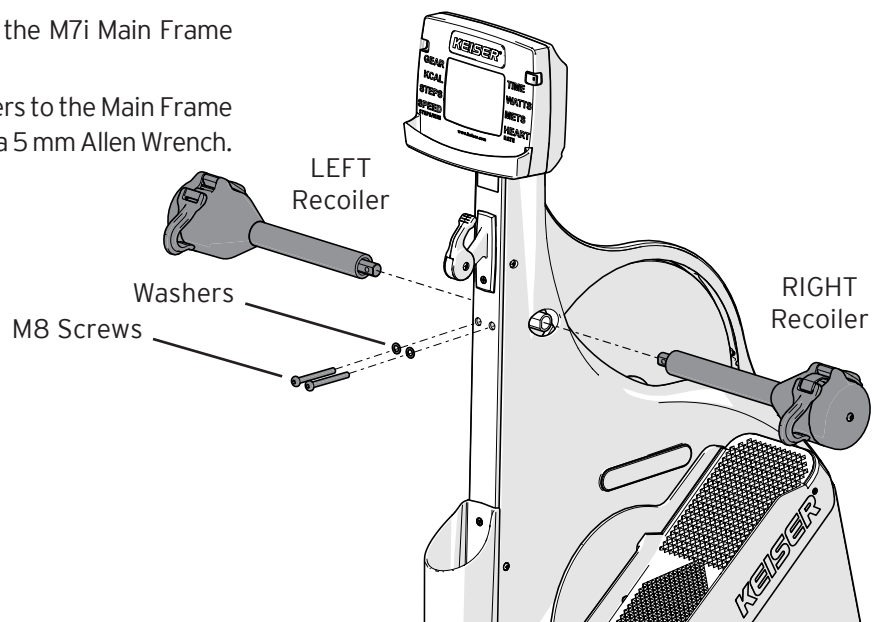

Figure 4. Recoilers Installation
(Arms are not shown for clarity)

Training Space

The equipment footprint is 38.5 inches x 28 inches (978 mm x 711 mm). The minimum amount of free space around the M7i is 36 inches (914 mm) on all sides, see Figure 5.

M7i equipment positioned adjacent to each other can share the recommended free space. Free space at the transport wheels end of the M7i is not required when positioned against a wall.

Additional free space may be required to accommodate mobility device access.

Transport

To transport the M7i, refer to Figure 6 and follow the instructions below:

1. Tilt the M7i onto the transport wheels by pushing the Display at the Keiser logo.
2. Steer the M7i by the Display from the rear to the desired location.
3. Hold the top of the Display from the front end, and slowly tilt the M7i forward to set down.

Placement

Place the M7i on a flat, level surface. Make sure the base makes full contact with the floor; adjust the Leveler Foot as needed (see "Leveler Foot" section on page 13 for instructions.)

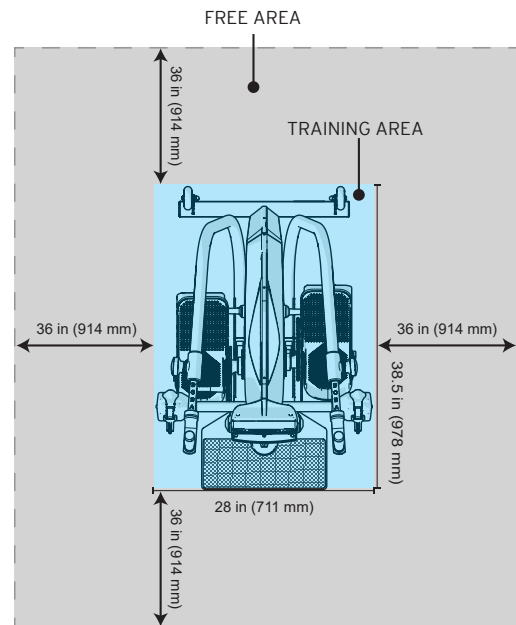

Figure 5. Training Area

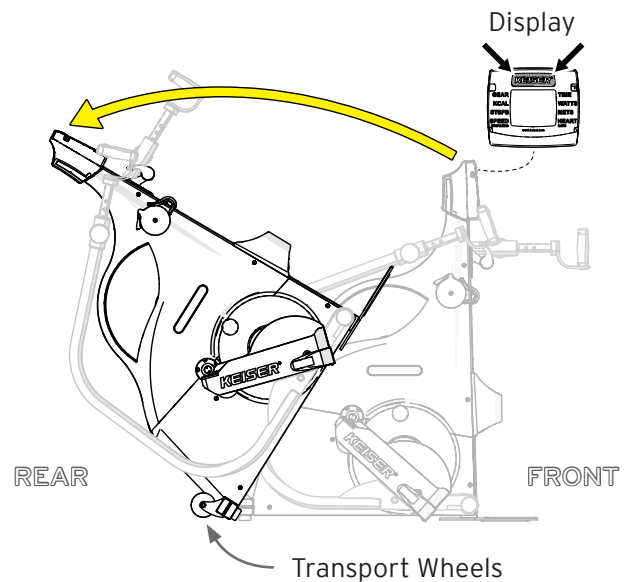

Figure 6. Transporting the M7i

SET UP AND OPERATION

PRODUCT OVERVIEW

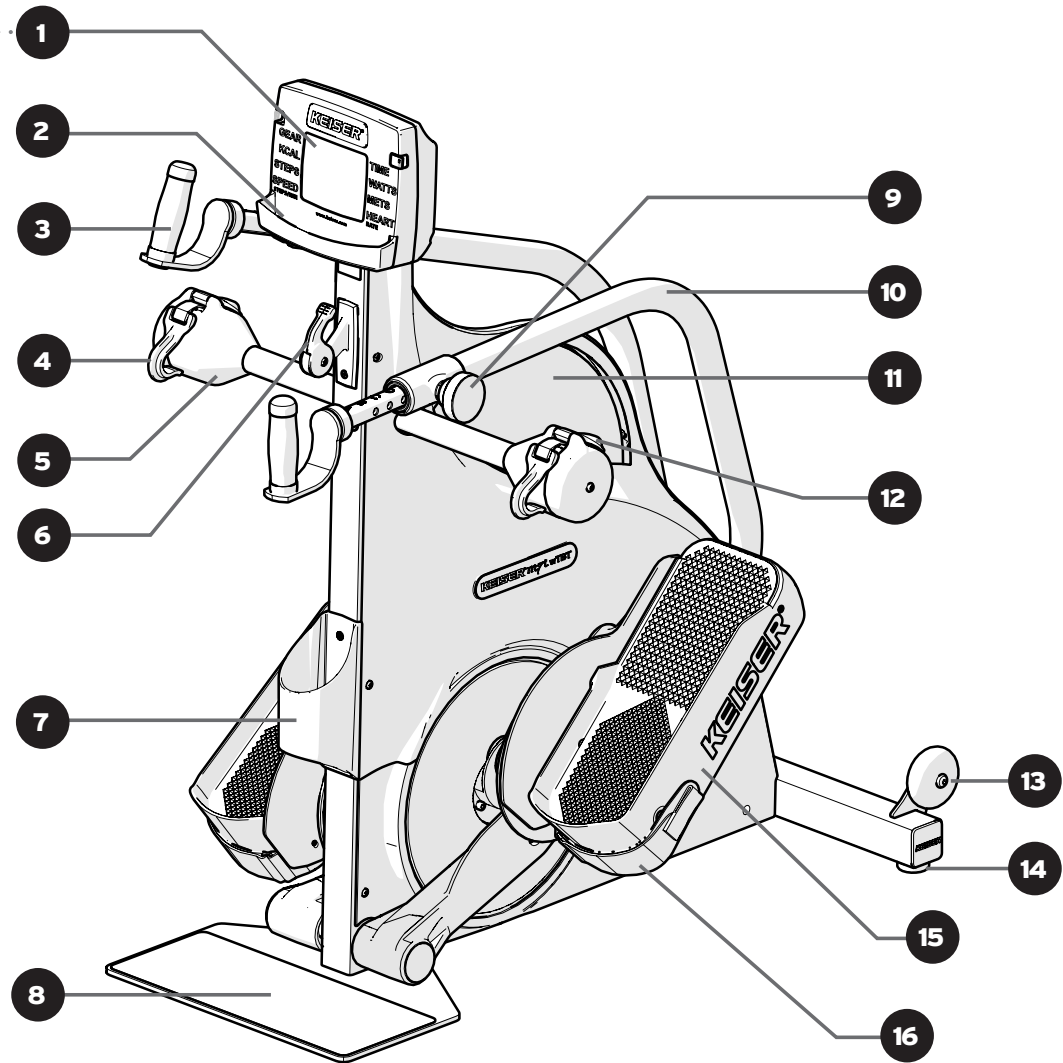

Figure 7. M7i Total Body Wheelchair Stepper

1	Computer System with Bluetooth [®] SMART	9	Adjustment Knobs
2	Valet Tray	10	Arms
3	Handles	11	Flywheel
4	Recoiler Safety Straps and Hooks	12	Lock Levers
5	Recoilers	13	Transport Wheels
6	Resistance Lever/Emergency Brake	14	Leveler Foot
7	Water Bottle Holder	15	Footpads
8	Base Plate	16	Foot Straps

PROPER OPERATION CHECK

If all assembly requirements have been met, and you have read and understood the Important Safety Instructions, test ride the M7i under the supervision of a spotter. Adjust and fine-tune as needed. It is recommended that the M7i is pedaled in a forward rotation.

M7i Proper Operation Check:

1. Computer Display powers ON at one full pedal revolution.
2. Left and Right Recoilers are installed correctly (refer to "Recoilers Installation" section, page 9).
3. Resistance Lever cycles GEAR 1–24 (GEAR 88 = Emergency Brake).
4. Adjustment Knobs properly engage into the Handle position holes and are hand-tight (refer to "Adjustment Knobs" section, page 14).
5. The M7i is properly stabilized, level to the floor (refer to "Leveler Foot" section, page 13).
6. Footstraps swivel up to position; no damage, wear, or broken parts detected. The hook and loop parts fasten properly.

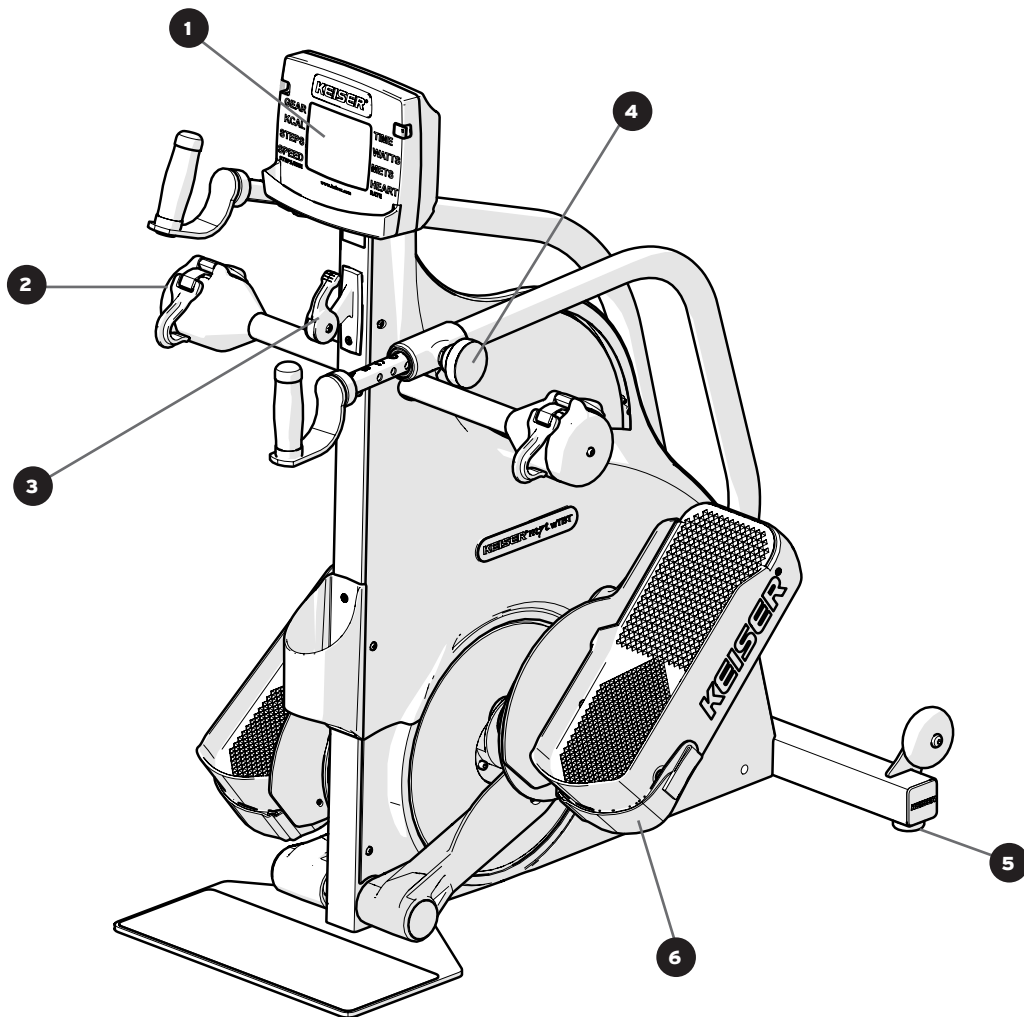

Figure 8. M7i Proper Operation Check

⚠ WARNING: To reduce the risk of serious injury, read all important precautions and instructions in this manual and all warnings on the M7i before operation. Failure to perform the Proper Operation Check prior to operation of the M7i will void your warranty and could result in serious injury.

The following pages are a brief overview of the features necessary for safe operation.

LEVELER FOOT

The M7i should be placed on a level surface. If the sub-floor is not level, the Leveler Foot allows adjustment to a position that will level your M7i.

Adjust the Leveler Foot by slightly lifting the right base corner of the M7i and screwing the foot in or out, refer to Figure 9.

- Rotate the Leveler Foot in (counterclockwise, from a topside view) to drive the foot further into the base.
- Rotate the Leveler Foot out (clockwise, from a topside view) to extend further out of the base.

Set the base corner down and test for stability. The M7i should sit flat without rocking. Adjust and fine-tune the Leveler Foot as needed.

NOTE: The M7i should not be used until it is level. If the M7i is transported to a different location, adjust the Leveler Foot as needed to level your M7i.

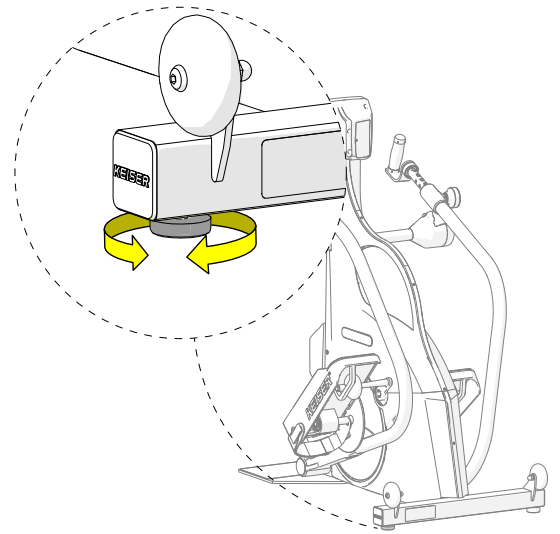

Figure 9. Leveler Foot Adjustment

RESISTANCE LEVER

Resistance is controlled by the Resistance Lever, refer to Figure 10. The Resistance Lever can be set to any gear from 1 to 24. The higher the gear number setting, the greater the resistance for the user.

EMERGENCY BRAKE

Move the Resistance Lever to the most forward position to engage the Emergency Brake. This will stop the motion of the Flywheel within one revolution, refer to Figure 10. Wait until the Footpads and Handles come to a complete stop before dismounting.

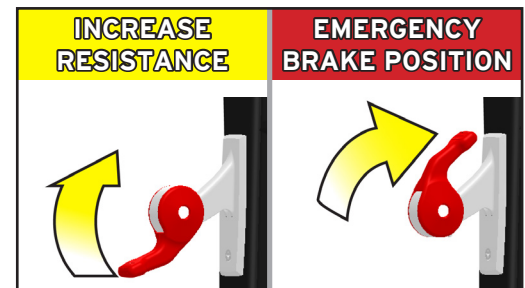

Figure 10. Resistance Lever and Emergency Brake Position

FOOTSTRAPS

Individuals with limited lower body control should always secure their feet with Foot Straps when operating the M7i. To set and fasten the Footstraps, refer to Figure 11 and follow the instructions below:

1. Place your foot under the Foot Strap and onto the Footpad with your heel resting against the rear wall of the Footpad.
2. Pull the Foot Strap end up and away from your foot to tighten the Foot Strap to your foot.
3. Press the hook and loop surfaces firmly together to fasten. Ensure the Foot Strap is snug to fit without causing discomfort.

⚠ CAUTION: Always wait for the M7i to come to a complete stop before attempting to adjust the Foot Straps.

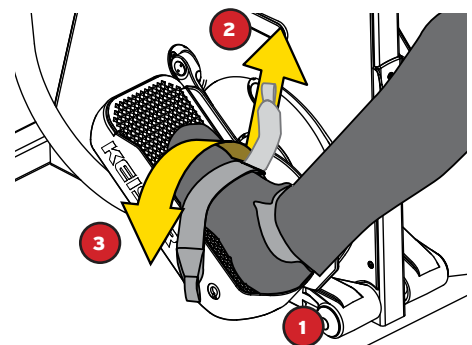

Figure 11. How to Fasten the Footstraps

ADJUSTMENT KNOBS

The Adjustment Knobs allow the Handles to adjust in increments of 1 inch (25 mm) to attain a comfortable reach distance. To set the Handles using the Adjustment Knobs, refer to Figure 12 and follow the instructions below:

1. Loosen the Adjustment Knob at least 1/2 turn counterclockwise.
2. Pull the Knob outward and hold.
3. Slide the Handle freely to the desired position.
4. Release the Knob. Ensure it locks into the desired position hole.
5. Turn the Knob clockwise until it is hand-tight to secure the Handle.

NOTE: For proper reach setting, ensure that your elbows maintain a slight bend when the Handles are pushed out to the furthest position.

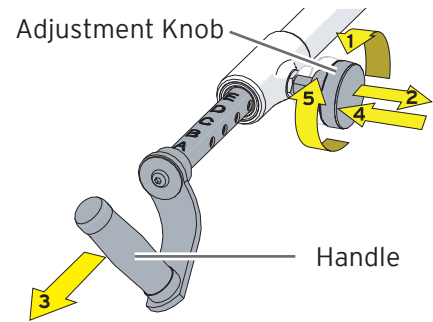
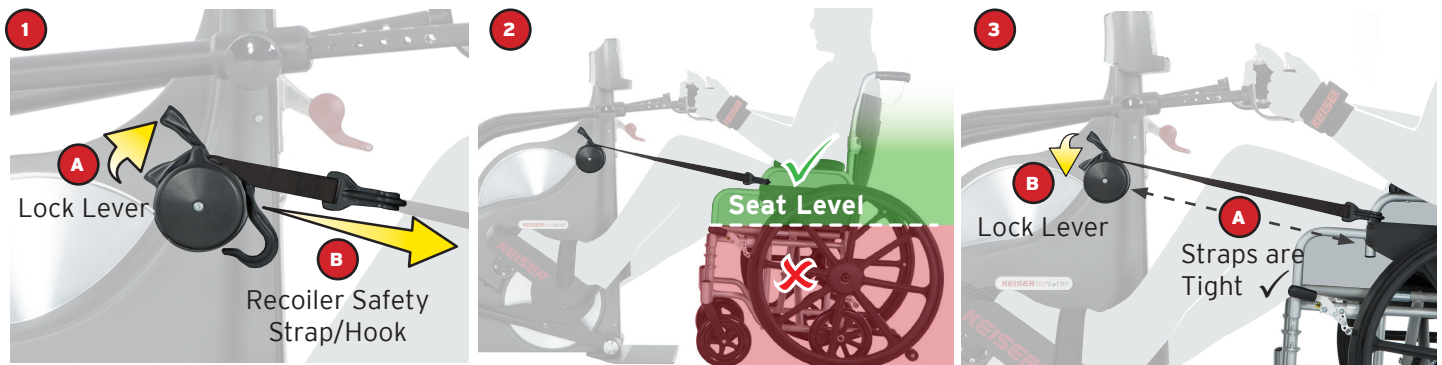

Figure 12. How to Adjust the Handles

RECOILER SAFETY STRAPS

Recoiler Safety Straps help increase wheelchair stability and must be used at all times during exercise. Wheelchair brakes must be locked during exercise (powered mobility devices turned off). To set the Recoiler Safety Straps, follow the instructions below.

WARNING: Sudden release of Recoiler Safety Straps in the unlocked position will snap back uncontrollably and could result in serious injury or equipment damage. Ensure the Lock Levers are in the locked position during use.



- (A) Lift the Recoiler Lock Lever up to unlock.
- (B) Pull the Safety Strap Hook out.

Attach the Safety Strap Hooks above Seat Level (e.g., arm rest).
CAUTION: TIP HAZARD. Safety Strap Hooks attached below Seat Level increases the chance of tipping backwards and could result in bodily injury. Always attach Safety Strap Hooks ABOVE SEAT LEVEL.

- (A) Check for tightly drawn Recoiler Safety Straps with no looseness.
- (B) Push the Recoiler Lock Lever down to lock in place. If your wheelchair feels like tipping back, stop in a controlled manner and repeat the entire procedure to adjust the Safety Straps until stability is achieved.

NOTE: When done exercising, lift the Recoiler Lock Lever up to unlock. Detach the Safety Strap Hooks and allow them to feed back into the Recoilers.

ACCESSORIES OPTIONAL EQUIPMENT



LEG STABILIZERS
 May be used to provide stability and to help ensure proper leg alignment and motion.
 Part Number: 520818 (qty 1)



ADAPTIVE WRIST STRAPS
 May be used when grip strength is limited or hand function is impaired.
 Part Number: 525408 (qty 1)

The M7i Adaptability Kit (PN 520800) includes a set of Leg Stabilizers (qty 2) and Adaptive Wrist Straps (qty 2).

COMPUTER DISPLAY

OVERVIEW

1 GEAR

Gears from 1–24 represent the resistance levels. The higher the gear number setting, the greater the resistance.

2 KCAL (KILOCALORIES)

Total energy expended during a workout session.

3 STEPS

Number of steps taken during a workout session.

4 SPEED

Interpreted as steps per minute (SPM), is the rate at which the user is pedaling.

5 TIME

Total time spent pedaling during a workout session.

6 WATTS

Power output generated, in real-time. The rated accuracy for power between 40 and 200 SPM is ± 5 Watts for power below 50 Watts, and $\pm 10\%$ for power above 50 Watts.

7 METS (Metabolic Equivalent of Task)

A MET is the ratio of the rate of energy expended during an activity to the rate of energy expended at rest.

Light-intensity aerobics defined as less than 2.9

Moderate-intensity aerobics defined as 3.0 to 5.9

Vigorous-intensity aerobics defined as 6.0 or greater

8 HEART

Displays heart rate in beats per minute (BPM).

When a sensor device is not in use, a steady heart symbol with a number value of zero will be displayed.

Compatible Heart Rate Sensors: POLAR® H9, POLAR® H10, or similar devices.

DISPLAY FEATURES

BACKLIGHT SENSOR

In awake mode, the backlight sensor automatically detects ambient light levels. The backlight will turn on to increase readability in low light conditions.

ODOMETER

For the first seven steps, the odometer will display the total distance traveled by the M7i (see Figure 14). This feature is for diagnostic purposes only. After the first seven revolutions, the odometer will disappear and the current workout data will be displayed.

WORKOUT DATA

Total Kcal, Steps, Watts, METs, and average Speed (Steps/Min) are viewable within 10 seconds after pedaling has stopped (NOTE: Heart Rate average available when using a heart monitor). The workout data will flash until pedaling resumes, however after 60 seconds of inactivity, the computer enters sleep mode and the data will reset.

Bluetooth® SMART ENABLED

The Bluetooth® SMART enabled computer allows Bluetooth® SMART Ready devices such as cellphones, tablets, and computers to gather workout information. M7i compatible apps allow data to be stored to track progress over time and make the data available to other wellness applications. Groups are able to utilize real-time performance tracking programs which give the entire group an opportunity to see their performance compared with others in the group.

Bluetooth® user notes: To receive and download workout information from your M7i, a machine ID number is required. The machine ID number you assign identifies your M7i for individual and in group Bluetooth discovery. The ID number is viewable within the first 10 revolutions (displayed as “id” and followed by any number 1 to 199 (see Figure 14). For Bluetooth® setup, see “How to Edit the Machine ID” procedure on page 17.



Figure 13. M7i Display Overview

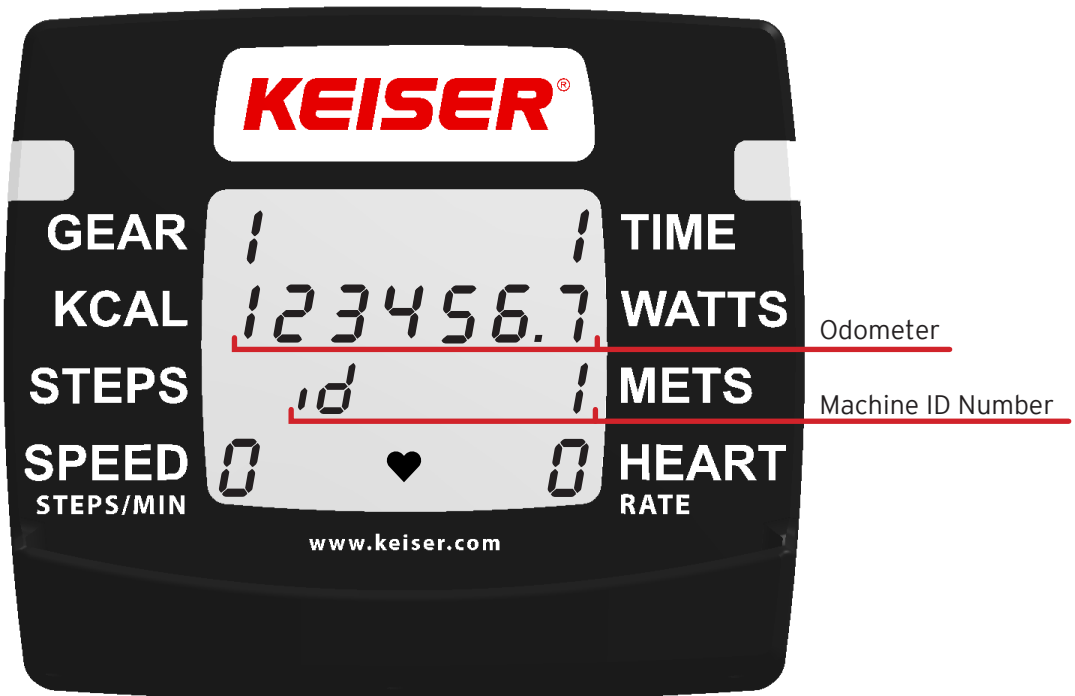

Figure 14. M7i Odometer and Machine ID Number

Note: For the first seven steps, the odometer will display the total distance traveled by the M7i. This feature is for diagnostic purposes only. After the first seven revolutions, the odometer will disappear and the current workout data will be displayed.



WARNING: Heart rate monitoring systems may be inaccurate. Over exercising may result in serious injury or death. If you feel faint stop exercising immediately.

HOW TO EDIT THE MACHINE ID

To receive and download workout information from your M7i to any Bluetooth® SMART Ready device, a machine ID number is required. The following is a one-time machine ID setup procedure. NOTE: Steps 1 through 7 must be completed within one minute.



Begin with the computer off and pull Resistance Lever all the way down towards you. This is GEAR "1" position.



Slowly pedal until the TIME value reads "1", then stop.



Shift the Resistance Lever up to GEAR "21".



Pedal 1 full revolution to change the TIME value to "2", then stop.



Shift the Resistance Lever down to GEAR "19".



Pedal 1 full revolution to change the TIME value to "3", then stop.

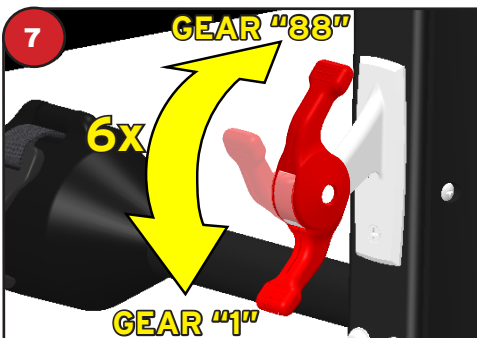

Shift the Resistance Lever from top to bottom (GEAR "88" to GEAR "1") for a total of 6 times.

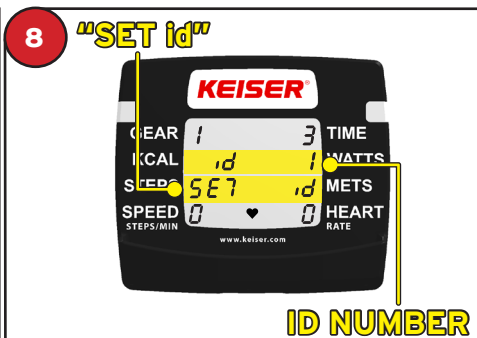

Upon successful completion of Steps 1-7, "SET id" will appear on the display.

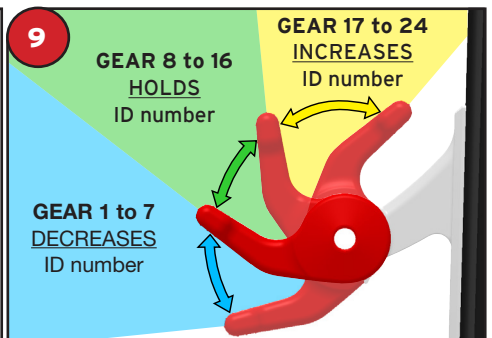

Set Machine ID ("id"):

- increases "id" number
- decreases "id" number

Set the "id" number to any number between 1 and 199.

To hold the "id" number, set to any GEAR number between 8 and 16 and allow the computer to sleep (1 minute estimated time).

IMPORTANT: The computer must be allowed to sleep to save the "id" number and exit the edit mode.

NOTE: If the computer shuts down at any time before Step 8, the setup has timed out. Restart the procedure from Step 1 at a time when Steps 1-7 may be completed within one minute.

Proceed to Step 9 to set ID number.

HOW TO EXERCISE ON THE M7i

The M7i is intended for cardiovascular, strength, and power conditioning exercise. The following sections outline the safe and proper operation of the M7i.

BIOMECHANICAL POSITION

Proper biomechanical positioning is necessary for a safe, comfortable, and effective workout. Follow the steps below to ensure proper biomechanical positioning before every workout:

1. **Wheelchair Position:** Feet are directly over the M7i Base Plate.
2. **Set Proper Reach:**
 - Legs – Place feet onto the Footpads, then extend one Footpad to the furthest position. Check for a slight bend at the knee and for minimal contact of your lower thigh with the seat. Adjust wheelchair position as needed.
 - Hands and Arms – Grab one Handle and extend it to the furthest position. With your back against the wheelchair backrest, check for a slight elbow bend. Adjust the Handle reach as needed for proper reach and comfort.
3. **Lock and Strap:** Once proper reach is attained, lock your wheelchair brake (turn off powered mobility devices) and attach the Recoiler Safety Straps (refer to page 14 “Recoiler Safety Straps” section).

Figure 15 “Biomechanical Positioning” shown below demonstrates proper positioning throughout your workout:

HANDS AND ARMS

Ensure a firm grasp throughout the exercise and that your elbows keep a slight bend at full extension. Keep your hands in front of your chest. Adjustable Handles allow users of varied heights to exercise comfortably. Swivel Handles allow wrists/shoulders to rotate naturally and freely.

HEAD AND NECK

Keep your head and neck in alignment with your body. Your eyes and ears should be on the same horizontal plane and parallel with the floor.

LEGS

At full leg extension, ensure that your knee keeps a slight bend and that your lower thigh makes minimum contact with the seat. Keep your legs in line with the Footpads. The legs should not be bowed out or inward.

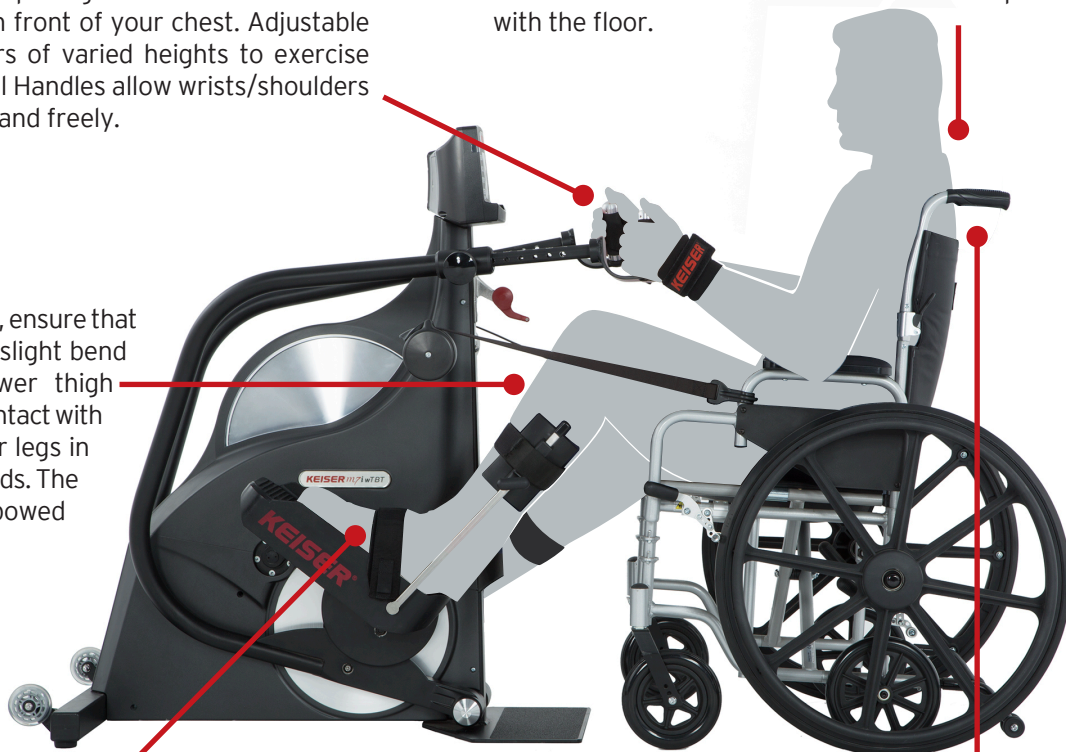

Figure 15. Biomechanical Positioning

FEET

Place your feet on the Footpads with heels resting against the Footpad rear wall. Foot Straps provide secure footing during exercise. NOTE: Ensure Foot Straps are snug to fit, without causing any discomfort.

BACK AND SHOULDERS

Your back must be fully supported by your wheelchair backrest at all times. Adjust any backrest support, cushion, or pillow for comfort. Avoid sitting at the edge of your seat. Maintain the natural curves of the spine and avoid leaning forward or arching your back to achieve proper posture.

Figure 15 above features optional Leg Stabilizers (PN 520818) and Adaptive Wrist Straps (PN 525408), available for individuals with limited control of legs or arms. Consult with your physician to determine if these items are right for you.

EXERCISE GUIDELINE

Consult your physician before beginning any exercise program. To help ensure a safe, comfortable, and effective workout, remember to:

1. **Warm up:** Proper warm up before you begin your workout helps to get your muscles ready for exercise and can help prevent serious injury.
2. **Control resistance:** Always work with resistance that you can handle through a full range of motion. Know your limitations.
3. **Breathe:** Keep your breathing at a constant but steady pace. Avoid holding your breath as this may cause physical harm.
4. **Keep your form and control:** Learn and know how to perform the exercise correctly. Keep a steady/fluid motion throughout your workout. If you are able, engage your abdominal muscles to help keep balance and protect your spine.

⚠ CAUTION: PROPER WARM UP REQUIRED TO HELP PREVENT SERIOUS INJURY. The M7i should only be used with proper instruction. Always maintain good form and control during exercise. If you feel pain or are unable to maintain good form, stop immediately. Failure to follow these instructions could result in serious injury. If you are unclear on proper form, consult a physical therapist or trainer.

EXERCISE POSITIONS

The M7i is intended for cardiovascular, strength, and power conditioning exercise. Always attempt exercises for the first time with the assistance of a spotter. Be aware of the potential for your wheelchair or mobility device to tip over in any direction. Supervision by a spotter is required if you have a physical complaint; a disability; or suffer from, have been diagnosed with, or have a family history of any disease or illness.

TOTAL BODY TRAINING (Figure 16) is an all-around exercise suited for users of any fitness level that provides a challenging, yet accessible, workout. The upper and lower body are engaged for cardiovascular and pulmonary endurance, as well as for strength and power conditioning.

INDEPENDENT UPPER BODY TRAINING (Figure 17) is an advanced workout position that focuses on upper body muscle groups for a high-intensity cardiovascular exercise. A firm grip and complete control of the Handles are required for optimal workout and to prevent injury. *Optional Adaptive Wrist Straps are available for individuals with limited or impaired grip (featured in Figure 15, page 18).*

INDEPENDENT LOWER BODY TRAINING (Figure 18) is a workout position that focuses on the lower body muscle groups for strength and power conditioning. Achieve a high-intensity cardiovascular exercise at higher SPMs. *Optional Leg Stabilizers are available for individuals with limited leg control (featured in Figure 15, page 18).*

Combine resistance and intensity, along with varied time durations, for your desired cardiovascular, strength, and power conditioning.

Remember: Take the time to pedal during cool down, and stretch after your workout. Download workout averages to any Bluetooth® SMART device with an M7i capable application.

⚠ CAUTION: Always secure the Foot Straps, Safety Recoiler Hooks, and Handles before starting your workout to prevent risk of serious injury.



Figure 16. Total Body Training Exercise Position



Figure 17. Upper Body Training Exercise Position



Figure 18. Lower Body Training Exercise Position

MAINTENANCE



CAUTION: SERVICE AND REPAIR SHALL ONLY BE PERFORMED BY KEISER-CERTIFIED TECHNICIANS.
Failure to follow these instructions can result in serious injury.

PREVENTATIVE MAINTENANCE SCHEDULE



CAUTION: THE HIGHEST LEVEL OF EQUIPMENT SAFETY CAN ONLY BE ENSURED IF THE EQUIPMENT IS REGULARLY INSPECTED FOR DAMAGE AND WEAR. Immediately replace damaged, worn, or broken parts. Do not use the equipment until all repairs have been completed and tested by a Keiser-certified technician.

Weekly	<ul style="list-style-type: none"> • Check to ensure that the M7i is in safe proper working order (perform “Proper Operation Check,” page 12). • Check that parts most susceptible to wear are not damaged or broken: Handles, Grips, Adjustment Knobs, Recoiler Safety Straps, Footpads, and Foot Straps. • Wipe all areas in the sweat path with a dry soft towel or cloth.
1st Month	<ul style="list-style-type: none"> • Check to ensure all external visible screws and nuts are not loose and that they are fastened tight. • Check for broken stitches or parts; torn, cut or frayed material; or locks, buckles, or hook and loop fasteners that do not hold securely.
Monthly	<ul style="list-style-type: none"> • Clean external surfaces using warm soapy water and a soft cloth, especially around the areas that come in contact with sweat. <ul style="list-style-type: none"> – Do not use household or industrial cleaners as they can destroy the paint finish. – For deeper cleaning, use only mild dish washing soap, followed by an automotive treatment such as Meguiar’s® Quik Detailer Mist and Wipe.
Biannually	<ul style="list-style-type: none"> • Check to ensure all external visible screws and nuts are not loose and that they are fastened tight. • Check Handles, Grips, Adjustment Knobs, Recoiler Safety Straps, Footpads, and Foot Straps and replace if worn. • The low battery signal (“LO-BA”) will appear on the computer display when it is time to replace the batteries (two D batteries per M7i, refer to “Computer Battery Replacement” on page 21 for complete instructions). NOTE: For establishments with multiple M7i machines, replacement of all computer batteries at the same time is recommended. • Apply wax to protect the paint finish on metal parts: <ol style="list-style-type: none"> 1. Wipe down and thoroughly clean the M7i prior to applying wax. 2. Use an easily applied automotive treatment such as Meguiar’s® Quik Detailer Mist and Wipe. 3. Target areas that come in contact with sweat as they are most vulnerable to rust. NOTE: Failure to apply a coat of wax to high-sweat areas at least twice annually will decrease paint and frame life due to corrosion and will void the warranty. • Apply lubricant to the Adjustment Knobs: <ol style="list-style-type: none"> 1. Unscrew Adjustment Knobs from the Arm. 2. Clean threads with a lint-free cloth. 3. Apply a moderate amount of lubricant to the threads. NOTE: Both the threaded stud and the threaded insert nut are stainless steel. It is critical to keep the threads lubricated with a heavy grease (preferably white or clear in color), such as HYDROTEX® Acculube #2 or any compound with equivalent anti-wear and corrosion resistant properties.

Contact Keiser Customer Support for replacement parts order, or for any matters regarding the safe operation of your M7i (see back cover for contact information).

COMPUTER BATTERY REPLACEMENT

Do not operate the equipment during battery replacement procedure. "Lo-bA" = Batteries are low, replace immediately.
NOTE: If batteries are dead (depleted), the Computer Display remains blank.

How to Replace the Batteries

To replace the batteries, refer to Figure 19 and follow the instructions below.

Tools Required: #1 Phillips Screwdriver and a flat, blunt object (e.g. a credit card).

1. Remove the battery compartment screw. Pry off the cover using a flat, blunt object.
2. Remove the 2 D batteries (follow manufacturer's recommendations for handling, maintaining, and disposing of batteries).
3. Install two new D batteries observing the correct polarity (see +/- marking inside the battery compartment). R6 (Zinc-Carbon) or LR6 (Alkaline) type batteries are acceptable. Do not use FR6 (Lithium) or similar type batteries.
4. Replace the battery compartment cover onto the computer housing and reinstall the screw.

Allow the Computer Display to enter sleep mode before use (estimated time: 1 minute).

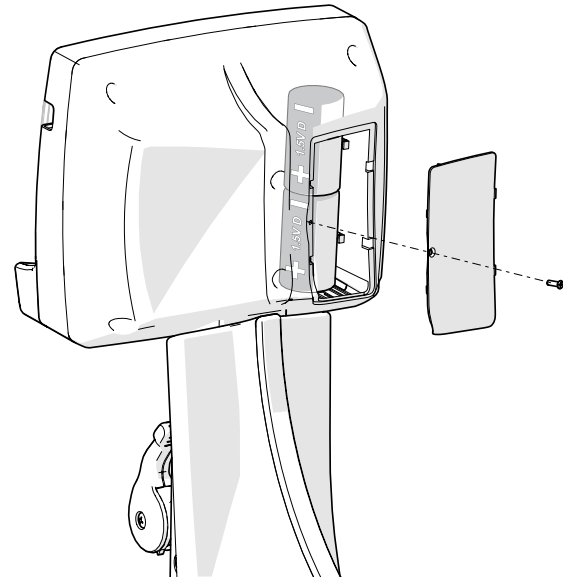

Figure 19. M7i Batteries Replacement

NOTE: Preserve battery life by removing the batteries for equipment storage or if the equipment is not expected to be used for extended periods of time.

⚠ CAUTION

Do not dispose of batteries in a fire. The batteries may explode.

Do not open or mutilate batteries. They contain an electrolyte which is toxic and harmful to the skin and eyes.

Replace batteries with the same number and type of batteries as originally installed in the equipment.

Recycle batteries in accordance with local recycling procedures.

STORAGE





1. Clean the machine to remove all dirt and dust.
2. Remove the batteries.
3. Place a cover over the machine to protect from dust and moisture.
4. Do not stack or store any items on top of, or leaning on, the machine.
5. Store indoors.

NOTE: Upon end of life of your M7i, contact Keiser Customer Support for handling direction (see back page for contact information). Be sure to follow your local government guidelines for battery disposal/recycling.

M SERIES CALIBRATION

All M Series equipment is factory calibrated. There is no need to calibrate. If a component associated with the resistance mechanism or computer has been replaced, contact Keiser Customer Support for the calibration procedure (see back cover for contact information).

REGULATORY AND COMPLIANCE NOTICES



Standards	ISO/EN 20957-1 Accuracy Class A (High accuracy) and Usage Class S (Studio, commercial use); IEC/EN 60601-1 and IEC/EN 60601-1-2.
Marks	   

BLUETOOTH® SMART word mark and logos are registered trademarks of Bluetooth SIG, Inc.; HYDROTEX® is the registered trademark of Hydrotex, Partners, Ltd.; MEGUIAR'S® is the registered trademark of Meguiar's, Inc.; and POLAR® is the registered trademark of Electro Oy.

SAFETY NOTIFICATIONS

Displayed watts testing parameters: “Kilocalories,” “Watts,” “Steps,” “METS,” and “Heart Rate” are not suitable for use in applications where the health and safety of a patient may be dependent on the accuracy of those parameters.

Clinical Settings Note: In clinical settings, patients may operate this equipment in accordance with this user manual and the instructions and guidance provided by the healthcare personnel responsible for supervising their treatment and care. However, patients shall not perform preventive maintenance, repairs or replace batteries on equipment installed in clinical facilities.

TYPE/DEGREE OF PROTECTION	CLASSIFICATION/IDENTIFICATION/WARNINGS	SYMBOL
The degree of protection against electric shock	The computer display is powered by 2 D cell alkaline batteries. Electrical safety evaluation conducted by TÜV SÜD per IEC/EN 60601-1 requirement.	
The degree of protection against the ingress of liquids	Not protected	N/A
The degree of safety in the presence of a flammable anesthetic mixture with air or with oxygen or nitrous oxide	Not suitable	N/A
The mode of operation	Continuous	N/A
Information regarding potential electromagnetic or other interference and advice regarding avoidance	The M7i uses electromagnetic and RF energy only for its internal function. Therefore, its EMC and RF emissions are very low and are not likely to cause any interference in nearby electronic equipment.	N/A
EMC Notices, Statement of Compliance	See Electromagnetic Compatibility (EMC) section, page 23.	N/A
ID of specified optional external power supplies or battery chargers	The M7i does not require an external power supply.	N/A
ID of any risks associated with the disposal of waste products, residues, including disposal of the equipment itself at the end of its useful life.	The M7i contains electronic circuit assemblies and 2 D cell alkaline batteries that may require compliance with specific local disposal or recycling procedures.	
The specification of the environmental conditions of transport and storage	Use indoor in climate-controlled environment only. Keep away from areas of extreme humidity. NOTICE: Equipment not tested at extreme high/low temperatures.	N/A

ELECTROMAGNETIC COMPATIBILITY (EMC)

EMC Notices – Statement of Compliance

This product has been determined to be compliant with the applicable standards, regulations, and directives for the countries where the product is marketed.

Compliance documentation, such as Declaration of Compliance for the product, are available upon request by contacting service@keiser.com. Please include the product, model number identifiers, and serial number and country that compliance information is needed in request.

Korea

이 기기는 가정용(B급)으로 전자파적합등록을 한 기기로서 주로 가정에서 사용하는 것을 목적으로 하며, 모든 지역에서 사용할 수 있습니다.

“This equipment is for home use and has acquired electromagnetic conformity registration, so it can be used not only in residential areas but also other areas.”

US FCC COMPLIANCE STATEMENT

NOTE: This equipment has been tested and found to comply with the limits for a Class B digital device, pursuant to part 15 of the FCC Rules. These limits are designed to provide reasonable protection against harmful interference in a residential installation. This equipment generates, uses and can radiate radio frequency energy and, if not installed and used in accordance with the instructions, may cause harmful interference to radio communications. However, there is no guarantee that interference will not occur in a particular installation. If this equipment does cause harmful interference to radio or television reception, which can be determined by turning the equipment off and on, the user is encouraged to try to correct the interference by one or more of the following measures:

- Reorient or relocate the receiving antenna.
- Increase the separation between the equipment and receiver.
- Connect the equipment into an outlet on a circuit different from that to which the receiver is connected.
- Consult the dealer or an experienced radio/TV technician for help.

DISPOSAL

 This equipment contains electrical or electronic components and alkaline batteries that must be disposed of properly to comply with the EU Directive on disposal of waste electrical and electronic equipment (EU WEEE Directive 2002/96/EC).

Contact an appropriate waste disposal company upon the equipment's end of service life. Disposal must be in accordance with respective national regulation.

Wear parts: After being replaced, wear parts must be disposed of according to country-specific waste laws.

If you have any questions about equipment disposal, please contact your local dealer or Keiser Customer Support (see back cover for contact information).

WARRANTY STATEMENT

View or print your M7i warranty online at keiser.com/support/warranty.

If you have any questions about your warranty, please contact Keiser Customer Support at 1 559 256 8000 or via live chat at keiser.com/support (Monday–Friday, 7 am to 5:30 pm Pacific Standard Time), or by email at service@keiser.com.

Customers outside the United States may obtain warranty information directly through a Keiser international distributor or dealer in the country of installation, or direct from Keiser's international division.

European Authorized Representative

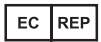

KEISER EUROPE SP. Z O.O.

ul. Starodworska 1
Gdańsk 80-137
Polska

UK Responsible Person (UKRP)

KEISER UK Ltd.

Unit 3, Hampton Industrial Estate
Hampton St., Tetbury
Gloucestershire, GL8 8LD
United Kingdom

CUSTOMER SUPPORT

If you have any questions regarding M7i installation or operation after reading this manual, contact Keiser Customer Support:

 1 559 256 8000

 service@keiser.com

 keiser.com/support

Telephone and Live Chat
Monday–Friday 7 am to 5:30 pm PST

Manufactured in the USA

KEISER CORPORATION

 2470 S. Cherry Ave.
Fresno, CA 93706